



# Public Notice

**U.S. Army Corps  
of Engineers**  
Pittsburgh District

In Reply Refer to  
Notice No. below

US Army Corps of Engineers, Pittsburgh District  
1000 Liberty Avenue  
Pittsburgh, PA 15222-4186

Application No. 2022-129

Date: March 11, 2022

Notice No. 22-20

Closing Date: April 11, 2022

1. TO ALL WHOM IT MAY CONCERN: The following application has been submitted for a Department of the Army Permit under the provisions of Section 10 of the Rivers and Harbors Act of 1899.
2. APPLICANT: Keystone Land Resources, Inc.  
46226 National Road  
St. Clairsville, Ohio 43950
3. LOCATION: Monongahela River, Alicia Docks Facility, river mile 58.2 to 58.9, right descending bank, Luzerne Township, Fayette County, Pennsylvania.
4. PURPOSE AND DESCRIPTION OF WORK: The applicant proposes renew their maintenance dredge permit, to preform maintenance dredging, as necessary, for a period of 10 years, at the Alicia Docks, along the bank of the Monongahela River. The proposed length and width of the area to be maintenance, is approximately 3,600 -feet-long by 110-feet-wide. The sediments will be dredged to the previously authorized depth of 12.5 feet below normal pool elevation of 743.5. The sediments will be removed using a barge-mounted clam-shell type dredge and will be disposed of at an approved offsite landfill. Drawings of the proposed dock are attached to this notice.
6. IMPACT ON NATURAL RESOURCES: The District Engineer has consulted the most recently available information and has determined that the project may affect but is not likely to adversely affect endangered species or threatened species or result in destruction or adverse modification of habitat of such species which has been determined to be critical. This Public Notice serves as a request to the U.S. Fish and Wildlife Service for any additional information they may have on whether any listed or proposed to be listed endangered or threatened species may be present in the area which would be affected by the activity, pursuant to Section 7(c) of the Endangered Species Act of 1972 (as amended). If the U.S. Fish and Wildlife Service concurs with the may affect, not likely to adversely affect determination please respond with written concurrence. *PNDI Project Search ID: PNDI-751993, 2/21/2022, No Known Impact , No Further Review Required .*

7. IMPACT ON CULTURAL RESOURCES: The National Register of Historic Places has been consulted, and it has been determined that there are no properties currently listed on the register which would be directly affected by the proposed work. If we are made aware, as a result of comments received in response to this notice, or by other means, of specific archeological, scientific, prehistorical, or historical sites or structures which might be affected by the proposed work, the District Engineer will immediately take the appropriate action necessary pursuant to the National Historic Preservation Act of 1966 - Public Law 89-665 as amended (including Public Law 96-515). *Pennsylvania State Historical and Museum Commission letter, dated March 1, 2022, gave a No Effect for both Above Ground Concerns and Archaeological Concerns.*

8. PUBLIC INVOLVEMENT: Any person may request, in writing, within the comment period specified in the paragraph below entitled "RESPONSES," that a public hearing be held to 246837 consider this application. The requests for public hearing shall state, with particularity, the reasons for holding a public hearing.

9. EVALUATION: Interested parties are invited to state any objections they may have to the proposed work. The decision whether to issue a permit will be based on an evaluation of the probable impact including cumulative impacts of the proposed activity on the public interest. That decision will reflect the national concern for both protection and utilization of important resources. The benefit which reasonably may be expected to accrue from the proposals must be balanced against its reasonably foreseeable detriments. All factors which may be relevant to the proposal will be considered including the cumulative effects thereof; among those are conservation, economics, aesthetics, general environmental concerns, wetlands, historic properties, fish and wildlife values, flood hazards, flood plain values, land use, navigation, shoreline erosion and accretion, recreation, water supply and conservation, water quality, energy needs, safety, food and fiber production, mineral needs, considerations of property ownership and, in general, the needs and welfare of the people.

The Corps of Engineers is soliciting comments from the public; Federal, state, and local agencies and officials; Indian Tribes; and other interested parties in order to consider and evaluate the impacts of this proposed activity. Any comments received will be considered by the Corps of Engineers to determine whether to issue, modify, condition or deny a permit for this proposal. To make this decision, comments are used to assess impacts on endangered species, historic properties, water quality, general environmental effects, and the other public interest factors listed above. Comments are used in the preparation of an Environmental Assessment and/or an Environmental Impact Statement pursuant to the National Environmental Policy Act. Comments are also used to determine the overall public interest of the proposed activity.

10. RESPONSES: A permit will be granted unless its issuance is found to be contrary to the public interest. Written statements concerning the proposed activity should be received in this office on or before the closing date of this Public Notice in

CELRP-RG  
Public Notice No. 22-20

order to become a part of the record and to be considered in the final determination. Any objections which are received during this period may be forwarded to the applicant for possible resolution before the determination is made whether to issue or deny the requested DA Permit. Public comments may be subject to release under the Freedom of Information Act (FOIA). All responses to this notice should be directed to the Regulatory Division, attn. George Brkovich at the above address, by telephoning (412) 395-7247, or by e-mail at [george.r.brkovich@usace.army.mil](mailto:george.r.brkovich@usace.army.mil). Please refer to CELRP-RG 2022-129 in all responses.

// SIGNED //

Jon T. Coleman  
Chief, South Branch  
Regulatory Division

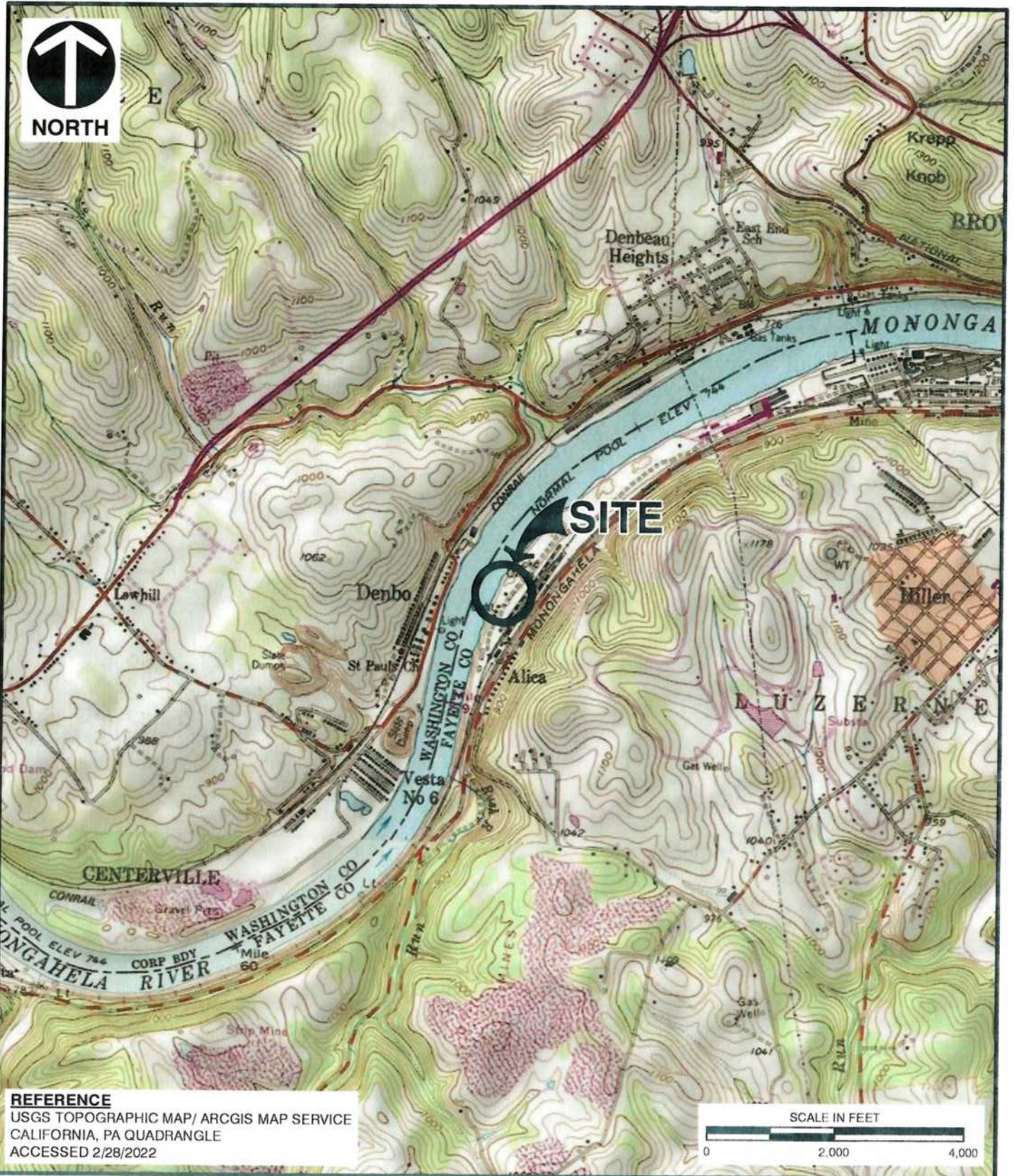

**REFERENCE**

USGS TOPOGRAPHIC MAP/ ARCGIS MAP SERVICE  
CALIFORNIA, PA QUADRANGLE  
ACCESSED 2/28/2022



**Civil & Environmental Consultants, Inc.**

333 Baldwin Road - Pittsburgh, PA 15205-9072

412-429-2324 • 800-365-2324

www.cecinc.com

KEYSTONE LAND RESOURCES, INC.  
ALICIA DOCK FACILITY  
FAYETTE COUNTY, PENNSYLVANIA

**SITE LOCATION MAP**

DRAWN BY:	CLC	CHECKED BY:	SMF	APPROVED BY:	* Hand signature on file	MLS*	FIGURE NO:	<b>1</b>
DATE:	2/28/2022	SCALE:	1" = 2,000'	PROJECT NO:	321-131			

P:\320-0\01321-131-GIS\Maps\ECC1321131\_EC01\_SITE.mxd 2/28/2022 9:52 AM (ccyprych)



Monongahela River  
FLOW

170'

3,600'



**LEGEND**

 PROPOSED DREDGING AREA

 PHOTO LOCATION



**REFERENCE**  
 ESRI WORLD IMAGERY / ARCGIS MAP SERVICE  
 ACCESSED 2/28/2022, IMAGERY DATE: 2020.



**Civil & Environmental Consultants, Inc.**  
 333 Baldwin Road - Pittsburgh, PA 15205-9072  
 412-429-2324 • 800-365-2324  
 www.cecinc.com

KEYSTONE LAND RESOURCES, INC.  
 ALICIA DOCK FACILITY  
 FAYETTE COUNTY, PENNSYLVANIA

**PROPOSED MAINTENANCE DREDGING**

DRAWN BY: CLC	CHECKED BY: SMF	APPROVED BY: <small>* Hand signature on file</small> MLS*	FIGURE NO: <b>2</b>
DATE: 2/28/2022	SCALE: 1" = 500'	PROJECT NO: 321-131	

P:\320-0\301321-131\GIS\Maps\EC01\321131\_EC01\_FIG2\_MAINTENANCE.mxd 2/28/2022 9:54 AM (ccyprych)

P:\320-000\321-131-CADD\LDWG\ENO1\321131-ENO1-TYPICAL SECTION.dwg[LAYOUT1] LS:(3/2/2022 -- mikovacic) -- LP: 3/2/2022 5:30 PM

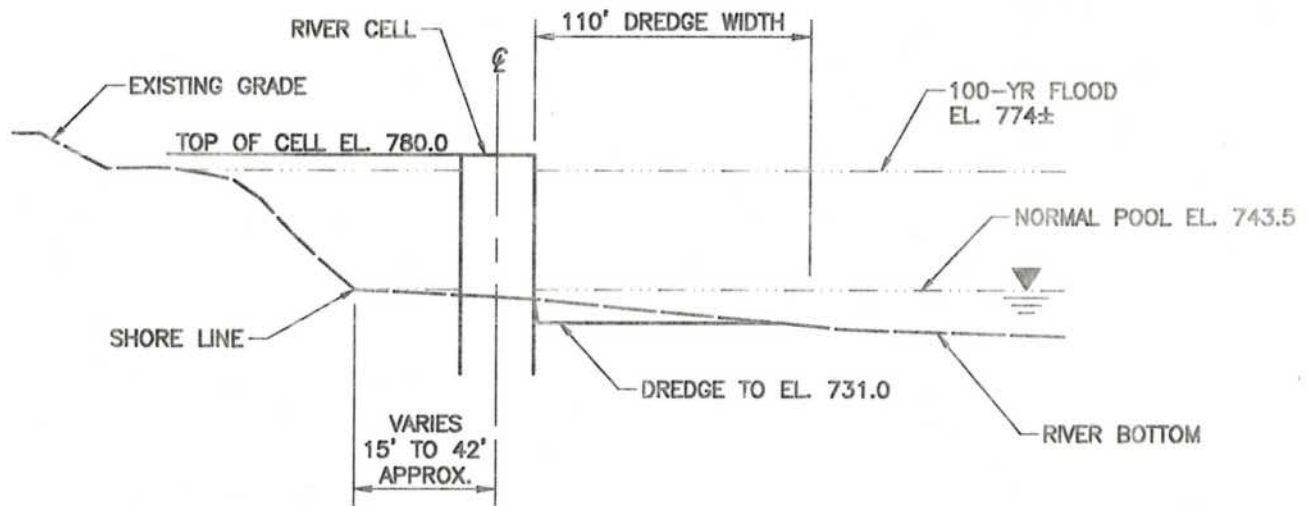

**TYPICAL SECTION**

\*HAND SIGNATURE ON FILE



**Civil & Environmental Consultants, Inc.**

333 Baldwin Road · Pittsburgh, PA 15205  
 412-429-2324 · 800-365-2324  
 www.cecinc.com

KEYSTONE LAND RESOURCES, INC.  
 ALICIA DOCK FACILITY  
 FAYETTE COUNTY, PENNSYLVANIA

TYPICAL SECTION

DRAWN BY:	DWD	CHECKED BY:	SMF	APPROVED BY:	MLS*	FIGURE NO.:
DATE:	3/2/2022	DWG SCALE:	NTS	PROJECT NO.:	321-131	<b>3</b>