

## **Guidance on Preparing and Providing Reproductions in Order to Forestall Possible Refusals on the Ground of Insufficient Disclosure of an Industrial Design by Examining Offices**

**(Rule 9(4) of the Common Regulations under the 1999 Act and the 1960 Act of the Hague Agreement)**

### ***GENERAL DISCLAIMER:***

*This Guidance is prepared in consultation with the Examining Offices under the Hague System. The purpose of this guidance is neither to be self-sufficient nor all inclusive; each guidance focuses on a separate issue elaborating ways to help the applicant to avoid a possible refusal. A table at the end of this Guidance indicates whether a specific guidance is recommended by a given Examining Office.*

## **CONTENTS**

### **I. NOT ENOUGH VIEWS**

GUIDANCE No. 1

- (a) Provide a sufficient number of views.
- (b) Provide explanations on the omitted views.
- (c) Provide views showing disclaimed part of the product.

### **II. UNCLEAR REPRESENTATIONS OF THE CLAIMED DESIGN**

GUIDANCE No. 2

Provide other specific views.

### **III. UNCLEAR RELIEF OR CONTOURS OF SURFACES OF A THREE-DIMENSIONAL PRODUCT**

GUIDANCE No. 3

Provide shading, hatching, dots or lines that may be used to indicate relief or contours of surfaces of a three-dimensional product.

### **IV. DIFFERENCE IN FORM/COLOR BETWEEN THE REPRESENTATIONS OF THE CLAIMED DESIGN**

GUIDANCE No. 4

No mixing of the reproductions in different forms; no mixing of the representations in black and white and in color.

## I. NOT ENOUGH VIEWS

Examining Offices may consider that the design has not been sufficiently disclosed if the whole configuration of the product in which the claimed design is embodied is not fully shown.

### EXAMPLE OF POSSIBLE PROBLEMATIC PRACTICE

The following example involves a bookstand. Only a certain part of the product is shown in the reproductions without any explanation regarding the lack of some views.

*Indication of the product: "Bookstand"*

1.1

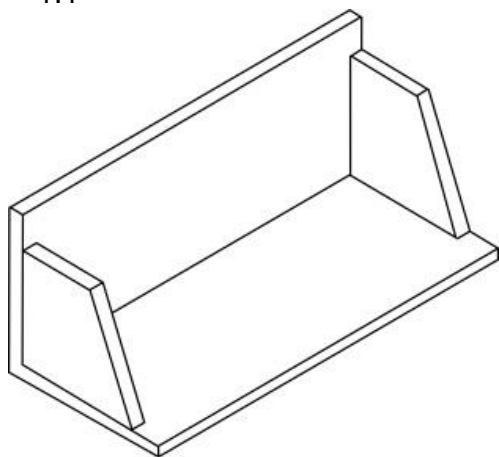

1.2



1.3

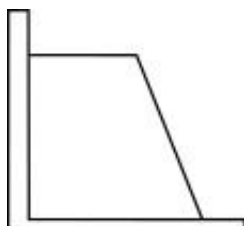

1.4



## GUIDANCE No. 1

(a) Provide a Sufficient Number of Views

(i) [Six] orthogonal views of a three-dimensional product from different directions (angles), which may encompass the following views: front, back, top, bottom, right side and left side, or two views showing the front surface and rear surface of a two-dimensional physical product (e.g. postcard, textile, etc.) may be submitted<sup>1 2</sup>.

(ii) Instead of [six] orthogonal views, perspective views may be submitted if the views show the entire configuration of the product<sup>3</sup>.

(iii) Each view should be of the same scale as the others<sup>4</sup>.

(iv) Appropriate legend (max 40 characters) or description indicating a direction (an angle) of each orthogonal view should be provided.

(v) When multiple designs are included in an application, each of the designs should be fully and independently disclosed through reproductions and/or description.

Illustrative Implementations Taking Into Account Guidance No. 1(a)*No. 1(a)(A) Six Views from Six Different Directions (Angles)*

1.1



1.2



<sup>1</sup> If a certain part of the claimed design cannot be clearly disclosed by those six views even in combination with any additional written description, other supplemental views should also be submitted at the time of filing (refer also to Guidance No. 2).

<sup>2</sup> Where Canada and/or Israel and/or Mexico and/or the United States of America is designated, it should be considered that they have no requirement pertaining to a strict numerical quantity of views (i.e., six views). Adequacy with respect to views is determined based on sufficiency of disclosure by those views but is not based on a numerical count of the views. Various designs and their attributes may each necessitate a different number of views to fully and completely disclose the design. If the subject matter that appears in a certain view forms no part of the claimed design, the submission of such a view is not required.

<sup>3</sup> Where Canada and/or Israel and/or the United States of America is designated, it should be reiterated that submission of either the six views or the two perspectives will not guarantee sufficiency of disclosure as this determination is not made dependent on a numerical count of views, but rather based on what is depicted. A combination of orthogonal views and perspective views may commonly be used to fully disclose the design.

<sup>4</sup> If a view shows a small part of the product (e.g. the top view of a pen) and the configuration may not be fully disclosed by that view, an “enlarged view” showing the part enlarged, in addition to that view, should also be submitted (refer also to Guidance No. 2).

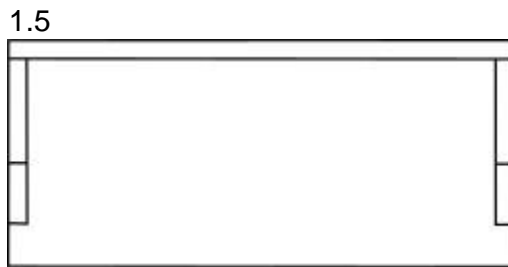
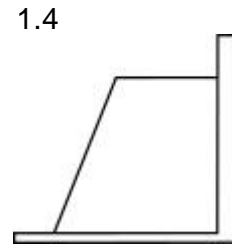
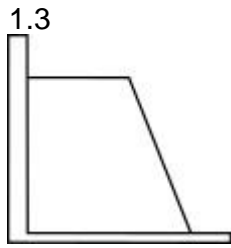

Legends/Description

1.1) Front; 1.2) Back; 1.3) Left; 1.4) Right; 1.5) Top; 1.6) Bottom.

OR

No. 1(a)(B) Two Perspective Views Showing All Surfaces of the Product

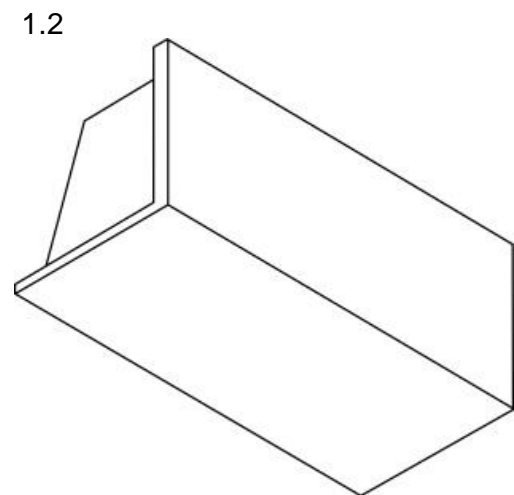
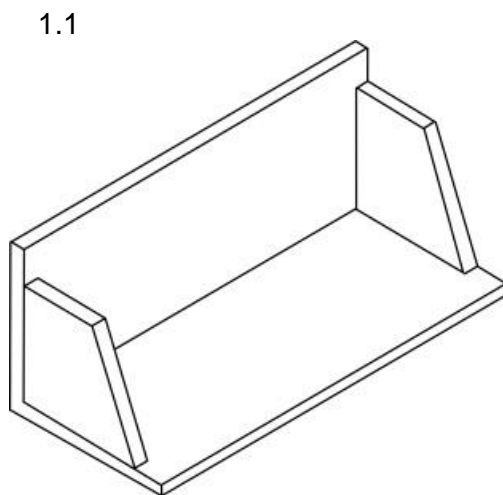

Legends/Description

1.1) Perspective (front, top, right); 1.2) Perspective (back, bottom, left)

## GUIDANCE No. 1

(b) Provide Explanations on the Omitted Views

Where the applicant wishes to omit a certain view which is an identical or mirror image of another view or which only shows a flat and non-ornamental surface of the product<sup>5</sup>, it should be clearly explained in the description which view is omitted and why that view is omitted<sup>6</sup>.

*The view of one side and another view of the opposite side are identical*

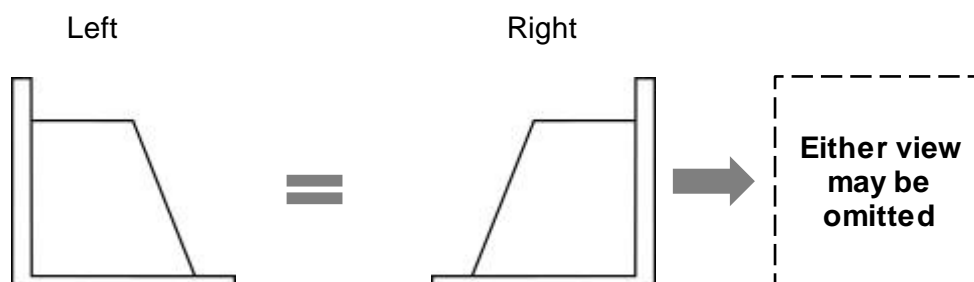

*The view on the back and the bottom has no ornamentation*

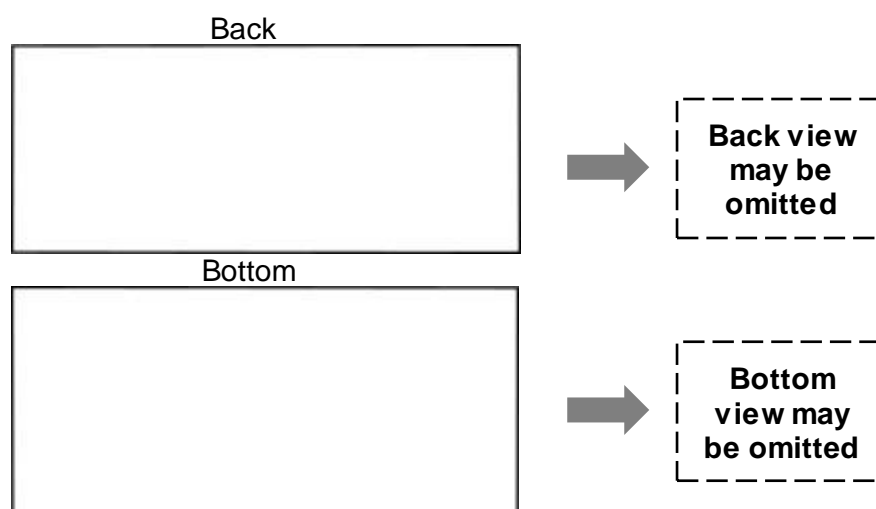

<sup>5</sup> Where Japan is designated, even if a certain view only shows a flat and non-ornamental surface of the product, it is not allowed to omit the view.

<sup>6</sup> Where Canada and/or Israel and/or the United States of America is designated, a description of the omitted view only needs to be provided where the omitted view includes subject matter that is part of the claimed design. If the omitted view forms no part of the claimed design, there is no need for the omitted view to be described in the description.

Illustrative Implementations Taking Into Account Guidance No. 1(b)*Three Views from Three Different Directions (Angles)*

1.1



1.2

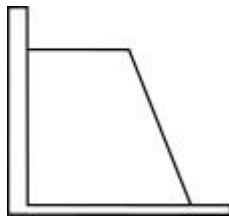

1.3

Legends

1.1) Front; 1.2) Top; 1.3) Left.

Description

A back view and bottom view are omitted because the surfaces of the back and the bottom of the product are flat and include no ornamentation. The right side view is omitted because it is a mirror image of the left side view.

## GUIDANCE No. 1

(c) Provide Views Showing Disclaimed Part of the Product

Where an applicant seeks protection of a certain part of the product:

(i) The entire configuration of the product may be represented in [six] orthogonal views or perspective views, even though protection is sought only for a certain part of it<sup>7</sup>. In those views, the disclaimed part of the product must be indicated by means of dotted or broken lines or coloring, according to Section 403 of the Administrative Instructions for the Application of the Hague Agreement.

<sup>7</sup> Where Canada and/or Israel and/or the United States of America is designated, portions of an article which have not been shown in the views and have not been otherwise described are considered to not form a part of the claimed design. For example, if the claimed design is directed to a bookstand and the back of the bookstand has not been shown or described, the back is simply considered excluded from the claim. Including a view showing the entire back in broken lines is not required.

(ii) An explanation on how the disclaimed part is indicated may be given in the description; if the disclaimed part is indicated with dotted or broken lines or coloring and no explanation is given on how to identify the disclaimed part of the design, it may create an ambiguity in the sense that the dotted or broken lines or color may be considered part of an integral element of the claimed design. For example, where broken lines are shown on a shoe without any explanation, it may be unclear whether the broken lines indicate a disclaimed part of the design or stitches on the shoe. Because dotted or broken lines may have a variety of meanings with respect to the claimed design, their meaning should be explained particularly when there is potential for ambiguity as to their meaning<sup>8</sup>.

### Illustrative Implementations Taking Into Account Guidance No. 1(c)

#### *No. 1(c)(A) Six Views from Six Different Directions (Angles)*

1.1



1.2

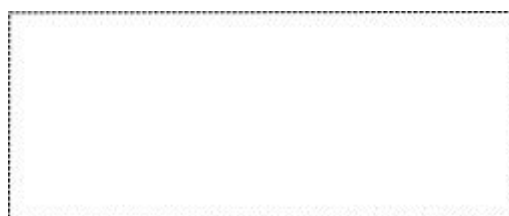

1.3

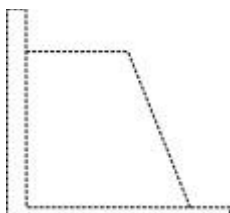

1.4

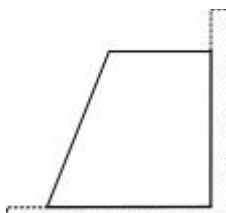

1.5

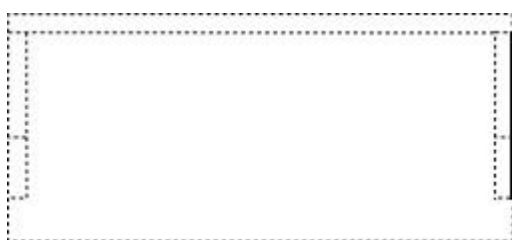

1.6

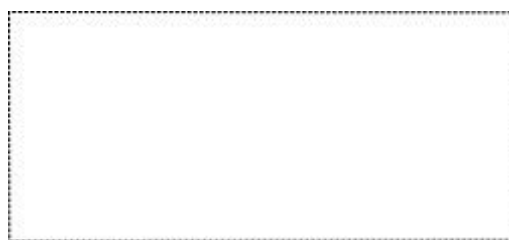

### Legends

1.1) Front; 1.2) Back; 1.3) Left; 1.4) Right; 1.5) Top; 1.6) Bottom.

<sup>8</sup> When Canada is designated, the use of coloring, dotted or broken lines may be considered a means of disclaiming. If the reproduction of the design contains dotted or broken lines illustrating elements that are meant to form part of the design such as stitching on a garment, a statement should be included in the application to ensure that the dotted or broken lines are interpreted as stitching or another design feature rather than a method of disclaiming features of the design. The same practice is recommended for coloring when it is actually meant to form part of the design.



Description

The parts shown by means of broken lines in the reproductions are not part of the claimed design.

OR

No. 1(c)(B) Two Perspective Views Showing All Aspects of the Product

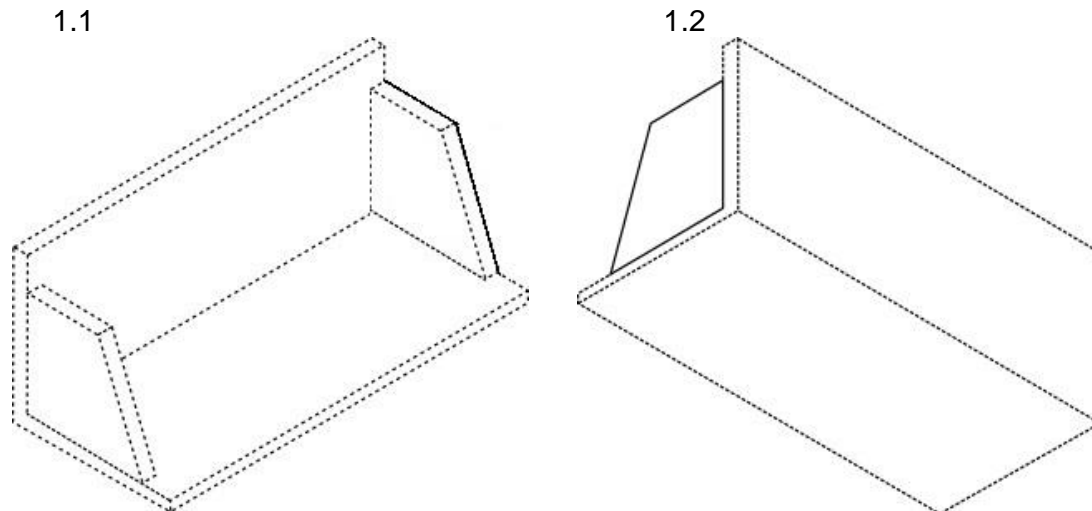
Legends

1.1) Perspective (front, top, left ); 1.2) Perspective (back, bottom, right).

Description

The parts shown by means of broken lines in the reproductions are not part of the claimed design.

## II. UNCLEAR REPRESENTATIONS OF THE CLAIMED DESIGN

It may be considered by Examining Offices that the design has not been sufficiently disclosed if the scope of the claimed design has not been clearly defined with the submitted views in combination with any additional written description.

### EXAMPLE OF POSSIBLE PROBLEMATIC PRACTICE

The following example depicts a storage box having an inner box and an inner lid. In this example, the internal configuration is not clearly shown. Patterns on the front surface are also not clearly shown.

- Although the overall appearance of the product is represented in the reproductions, contours or the configuration of a certain part have not been clearly disclosed.
- Where it seems that a certain part of the product is movable or may be opened and closed, the configuration of the said part which is not seen at a certain view angle has not been disclosed.

*Indication of the product: "Storage box"*

1.1

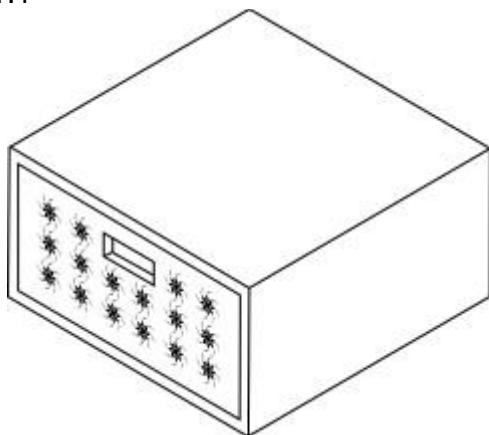

1.2

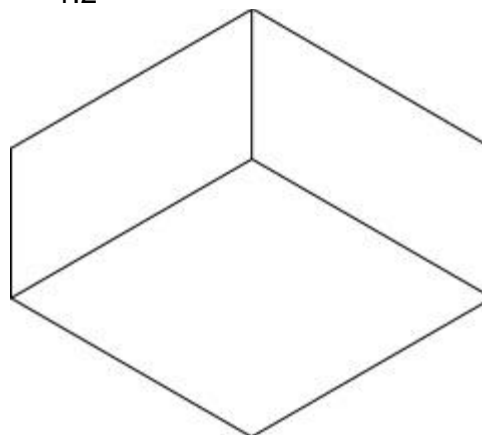

1.3

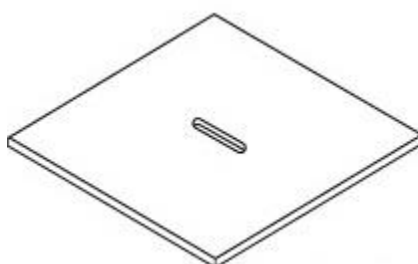

Legends/Description

1.1) Perspective view (front, top, right side); 1.2) Perspective view (back, bottom, left side); 1.3) Perspective view of the inner lid.

GUIDANCE No. 2

Provide Other Specific Views

(a) For a clearer disclosure of the configuration of a certain part of the product, where necessary to adequately disclose the design, other specific views such as (partially-) enlarged view, exploded view, cross-sectional view, view showing a state where the product has transformed, etc., in addition to standard views showing the appearance of the whole product (refer to Guidance No. 1(a)), should be submitted at the time of filing.

(b) An appropriate legend or description of the other specific view should be provided to avoid any ambiguity. For example, the representations may be considered inconsistent with one another if a certain part of the product is represented largely in a view without an indication of "enlarged view" because the view is deemed to be different in scale from the other views.

(c) When an enlarged view or cross-sectional view is submitted, an indication of which portion of the product is shown in those views should be given in the description or in the corresponding legend.

Illustrative Implementations Taking into Account Guidance No. 2

1.1

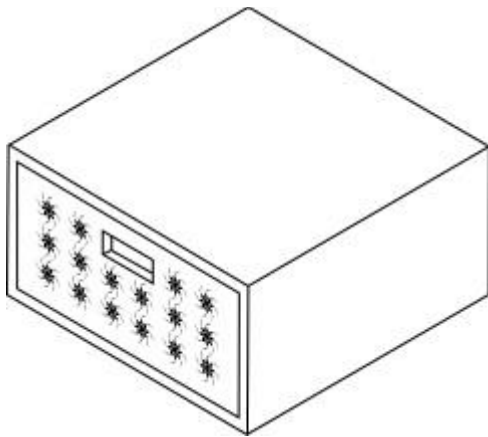

1.2

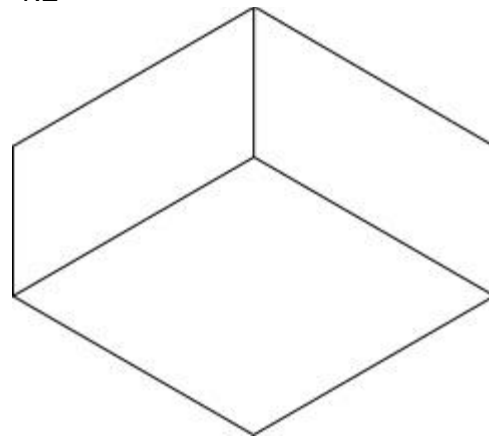

1.3

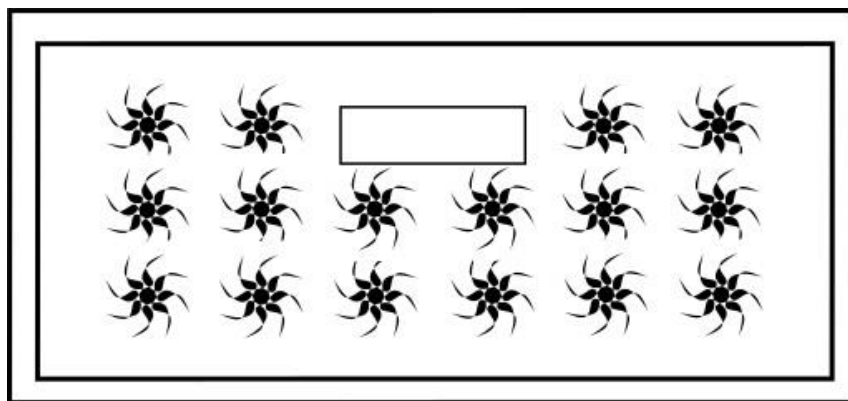

1.4

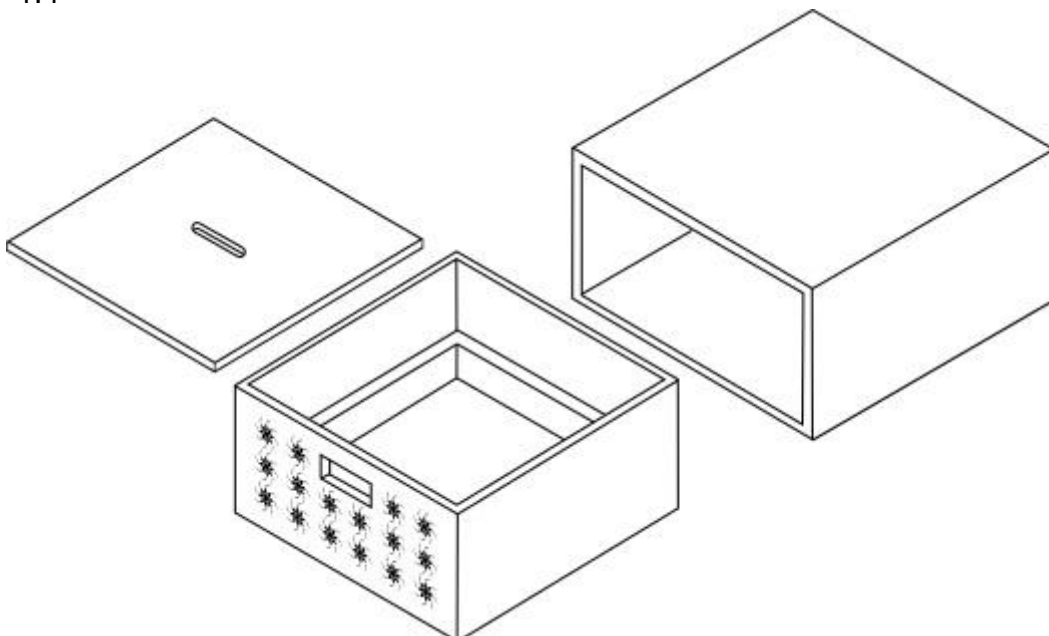

1.5

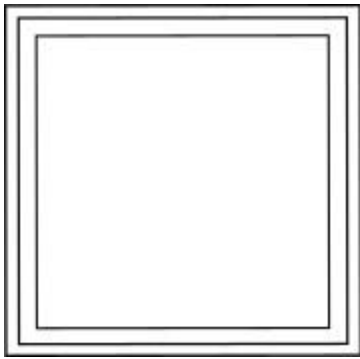

1.6



1.7



1.8

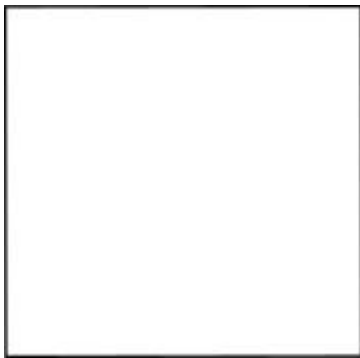

1.9

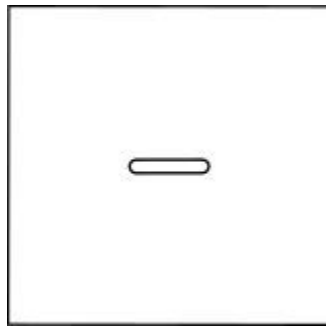

1.10



1.11

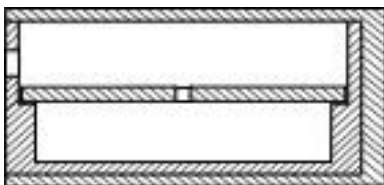

### Legends/Description

1.1) Perspective (front, top and right); 1.2) Perspective (back, bottom and left); 1.3) Enlarged front view; 1.4) Exploded view; 1.5) Top of the inner box; 1.6) Back of the inner box; 1.7) Left of the inner box; 1.8) Bottom of the inner box; 1.9) Bottom of the inner lid; 1.10) Front of the outer case; 1.11) Cross-sectional view<sup>9</sup>.

<sup>9</sup> Where Canada and/or Japan and/or Mexico and/or the United States of America is designated and an applicant utilizes a cross-sectional view, it is recommended that the location of the cross-section be identified visually in the figure and/or through description (e.g., "Cross-sectional view taken through front to back center" or "Cross-sectional view sectioned vertically at the center of the front view").

### III. UNCLEAR RELIEF OR CONTOURS OF SURFACES OF A THREE-DIMENSIONAL PRODUCT

It may be considered by Examining Offices that the design has not been sufficiently disclosed if the scope of the claimed design has not been clearly defined with the submitted views in combination with any additional written description.

#### EXAMPLE OF POSSIBLE PROBLEMATIC PRACTICE

The contours of a three-dimensional product with curved surfaces have not been clearly shown in the representation since shading is not provided in the drawings.

*Indication of the product: "Pharmaceutical tablet"*

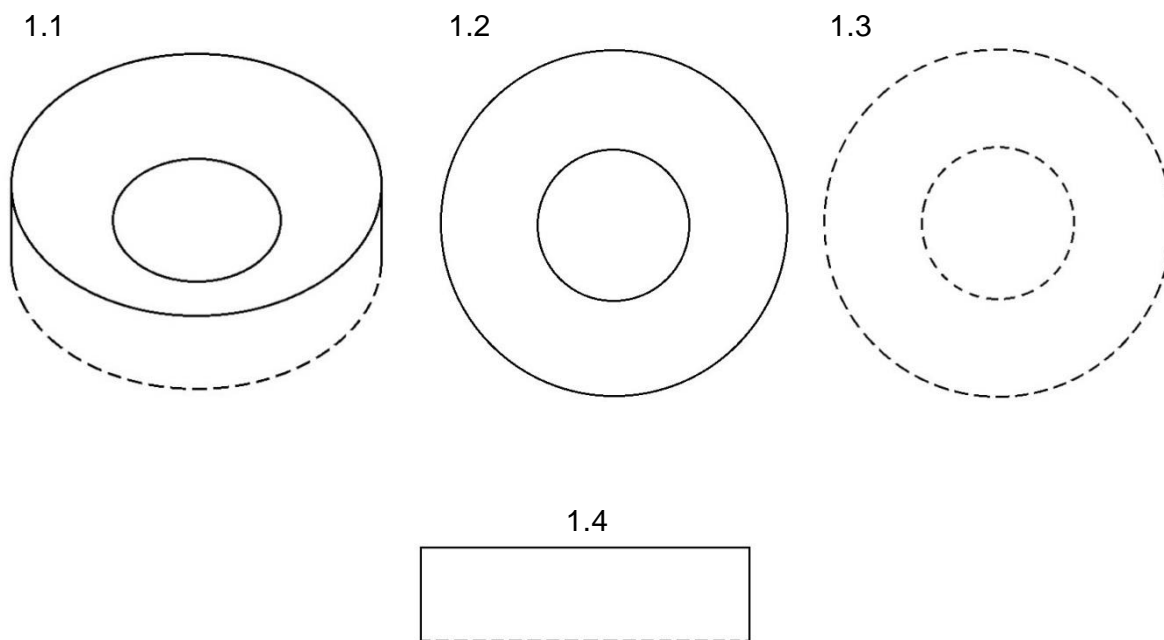

#### Legends

1.1) Perspective (front, top and right); 1.2) Top; 1.3) Bottom; 1.4) Front.

#### Description

The parts shown by means of broken lines in the reproductions are not part of the claimed design. The left side view, the right side view and the back view are omitted because they are identical with the front view, respectively.

## GUIDANCE No. 3

Provide Shading, Hatching, Dots or Lines that May Be Used to Indicate Relief or Contours of Surfaces of a Three-Dimensional Product

(a) Shading, hatching, dots, or lines should be provided in the representations<sup>10</sup> where it is difficult to represent relief or contours of surfaces of a three-dimensional product without them<sup>11</sup>.

(b) Shading, hatching or lines should not be provided on unclaimed subject matter where they may lead to confusion as to the scope of the claimed design.

(c) The purpose of the shading, hatching or lines provided in the representations should be clearly stated in the description in order to avoid any confusion with patterns on the surfaces<sup>12</sup>.

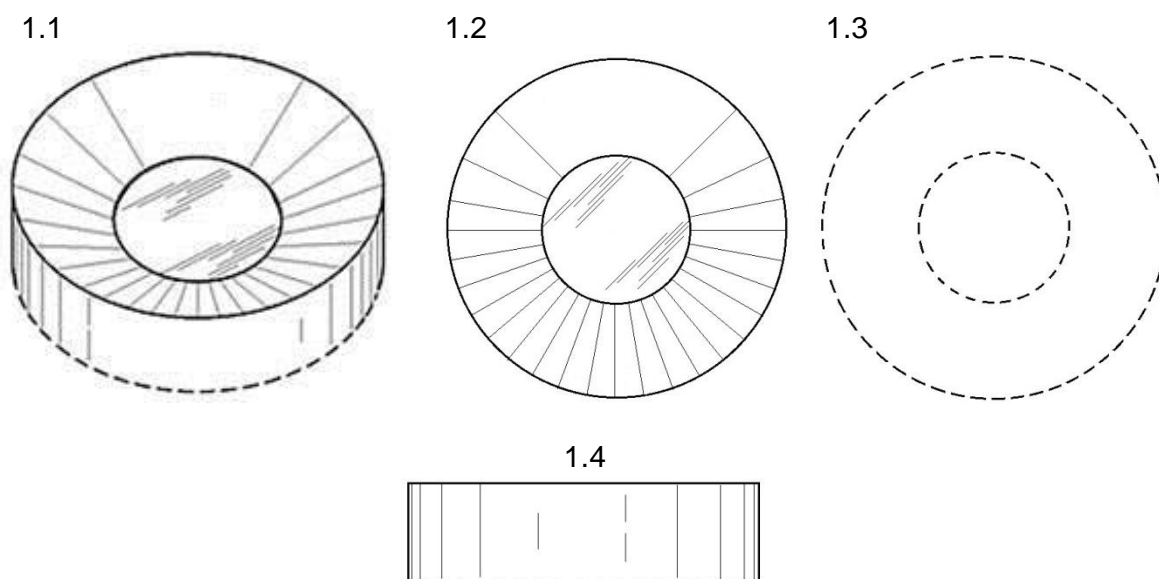
Illustrative Implementations Taking Into Account Guidance No. 3Legends

1.1) Perspective (front, top and right); 1.2) Top; 1.3) Bottom; 1.4) Front.

<sup>10</sup> Renderings in a computer graphic representation can be used as an alternative to shading, hatching, etc. to represent relief or contours of surfaces of a three-dimensional product.

<sup>11</sup> Where Japan is designated, it should be noted that submitting sectional views or perspective views to represent relief or contours of surfaces of the product concretely is a more preferable way than providing shading, hatching, etc. in the representation.

<sup>12</sup> Where Canada and/or the United States of America is designated, it should be noted that sometimes shading or hatching or other lines may be self-explanatory and sometimes shading or hatching or other lines will need further explanation for the design to be fully disclosed and understood.

### Description

The parts shown by means of broken lines in the reproductions are not part of the claimed design. The parallel thin lines and the radial thin lines in the representation represent contours only and do not illustrate an ornamentation or decoration on the surface of the product. The left side view, the right side view and the back view are omitted because they are identical with the front view, respectively.

#### **IV. DIFFERENCE IN FORM/COLOR BETWEEN THE REPRESENTATIONS OF THE CLAIMED DESIGN**

It may be considered by Examining Offices that if one (or some) of the reproductions are in a different form or only one (or some) of the representations are in color, the contents of the claimed design shown in all the reproductions, such as color, pattern, etc., are inconsistent with each other.

#### **EXAMPLE OF POSSIBLE PROBLEMATIC PRACTICE**

- At least one of the reproductions of an industrial design is a photograph. The remaining ones are line drawings.
- At least one of the reproductions of an industrial design is a line drawing. The remaining ones are computer graphic representations.
- At least one of the representations of an industrial design is in color. The remaining ones are in black and white.

*Indication of the product: "Cup"*

1.1



1.2



Note: reproduction 1.1 is a line drawing while reproduction 1.2 is a computer graphic representation in color.

## GUIDANCE No. 4

No Mixing of the Reproductions in Different Forms; No Mixing of the Representations in Black and White and in Color

- (a) All reproductions should be in the same form<sup>13</sup>.
- (b) Representations should be all in either black and white or color.

Illustrative Implementations Taking Into Account Guidance No. 4

Design 1 is represented in the form of a line drawing and design 2 is represented in the form of a computer graphic representation in the same international application. Design 1 is in black and white and design 2 is in color.

1.1

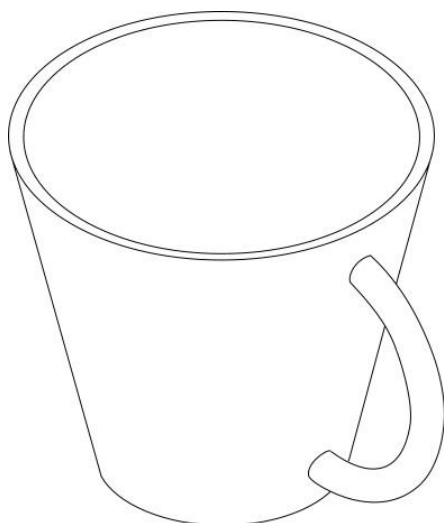

2.1



---

<sup>13</sup> Where Canada and/or Japan and/or Romania is designated, mixing the reproductions of a design in different forms is accepted unless the examiner finds an inconsistency in color, pattern, or other elements of the design between those reproductions.



LIST SHOWING WHICH GUIDANCE SHOULD BE TAKEN INTO ACCOUNT  
WHEN DESIGNATING A GIVEN CONTRACTING PARTY

GUIDANCE	CA	HU	IL	JP	KG	KR	MD	MX	RO	RU	SY	US
	<b>GUIDANCE No. 1</b>											
<b>(a)(i)</b> Submit six views of a three-dimensional product or two views of a two-dimensional product.	*		*	⊙		○	○	*	⊙	*	⊙	*
<b>(a)(ii)</b> Submit perspective views instead of six views.	*	○	*			○	○	○	○	*	○	*
<b>(a)(iii)</b> Make views to be in the same scale	○		⊙	⊙		○	⊙	○	⊙	⊙	⊙	○
<b>(a)(iv)</b> Indicate the direction (angle) of each view.	○	X	⊙	⊙		○	○	○	⊙	⊙	⊙	⊙
<b>(a)(v)</b> Submit a sufficient number of views for each of the multiple designs	⊙	⊙	⊙	⊙		⊙	○	⊙		⊙	○	⊙
<i>In a situation where an applicant wishes to omit a certain view(s):</i>												
<b>(b)</b> Explain which view(s) are omitted and why they were omitted.	*	X	*	⊙		⊙	○	X	○	X	⊙	*
<i>In a situation where an applicant seeks protection of a certain part of the product:</i>												
<b>(c)(i)</b> Submit view(s) of a part(s) of the product for which protection is not sought, showing it by means of a disclaimer.	⊙	⊙	*	⊙		⊙	⊙	⊙	⊙	⊙	⊙	*
<b>(c)(ii)</b> Explain the means to indicate the disclaimed part.	⊙	○	⊙	⊙		○	○	○	⊙	⊙	⊙	⊙
<b>GUIDANCE No. 2</b>												
<b>(a)</b> Submit another specific view at the time of filing for a clearer disclosure of the configuration of a certain part of the product where necessary to adequately disclose the design.	⊙	⊙	⊙	⊙		○	○	○	○	○	⊙	⊙
<b>(b)</b> Provide an appropriate legend/description of the other specific view.	⊙	X	⊙	⊙		○	○	○	○	○	⊙	⊙
<b>(c)</b> Indicate which portion of the product is shown in a cross-sectional or enlarged view.	⊙	X	⊙	⊙		○	⊙	⊙	○	○	⊙	⊙
<b>GUIDANCE No. 3</b>												
<b>(a)</b> Provide shading, hatching or lines that may be used to indicate relief or contours of the surface of the product.	⊙	○	○			○	○	○	○	○	○	⊙
<b>(b)</b> Do not provide shading, hatching or lines on unclaimed subject matter where they lead to confusion as to the scope of the claimed design.	⊙	⊙	⊙				⊙	⊙		⊙	X	⊙
<b>(c)</b> Explain the purpose of the shading, hatching or lines provided in the representation.	○	X		⊙		○	○	X	○	○	⊙	○
<b>GUIDANCE No. 4</b>												
<b>(a)</b> No mixing of reproductions in different forms.	*	⊙	⊙	○		○	○	○	○	⊙	○	⊙
<b>(b)</b> No mixing of representations in black and white and in color.	⊙	⊙	⊙	⊙		○	⊙	○	○	⊙	⊙	⊙

⊙: Highly recommended    ○: Recommended    X: Not recommended    \*: Appropriateness of use is dependent on circumstances. Refer to detailed guidance.

CA: Canada; HU: Hungary; IL: Israel; JP: Japan; KG: Kyrgyzstan; KR: Republic of Korea;  
MD: Republic of Moldova; MX: Mexico; RO: Romania; RU: Russian Federation; SY: Syrian Arab Republic;  
US: United States of America.