

# Cloud Providers and the VMware Cloud Director Service Delivery Platform 10.3 update

Guy Bartram

Director Product Marketing VMware Cloud Director

July 2021

## Table of Contents

What is VMware Cloud Director? .....	3
How can you consume Cloud Director? .....	3
Asset Heavy .....	3
Asset Lite .....	3
Why do you need Cloud Director? .....	4
How Cloud Director addresses efficiency .....	4
How Cloud Director addresses increasing revenue .....	5
How Cloud Director addresses differentiation .....	6
How Cloud Director addresses risk reduction .....	7
But, why now? .....	8
How does VMware Cloud Director address customer consumption? .....	9
Pay-As-You-Go cloud .....	10
Allocation pool of resources .....	10
Reservation Pools of resources .....	10
Flex Allocation model .....	11
VMware Cloud Director extensibility .....	11
UI extensibility for VMware Cloud Director .....	11
Disaster Recovery from VMware Cloud Director Availability .....	12
Dell Data Protection for VMware Cloud Director .....	12
S3 Object Storage via Object Storage Extension .....	12
Kubernetes Cluster Services and the Container Service Extension .....	12
Deliver Bitnami applications to your tenants .....	13
Provide your customer applications via App Launchpad .....	13
Infrastructure as code with Terraform Provider .....	13
Operational Automation Extensibility within Cloud Director .....	13
Delivering monitoring and chargeback to the customer .....	13
Monitoring .....	13
Chargeback .....	14

## What is VMware Cloud Director?

In essence, VMware Cloud Director is a service delivery platform that uses logical constructs to facilitate multitenant virtual infrastructure resources and services to self-service tenants. Cloud Providers need optimization of assets to maximize margins and return. To do this, they need to share resources securely to multiple tenants, providing both private and public hybrid clouds. There is a huge opportunity for cloud providers in a growing market for cloud services.

Whilst VMware Cloud Director started life providing Infrastructure as a Service (IaaS), it has continued to innovate and evolve above and beyond just IaaS into applications and cloud native solutions that we will discuss in this document.

Approx. **1140** Cloud Providers run VMware Cloud Director and are growing on average **12%** faster than those who don't!  
(VMware, 2021)

In its purest form VMware Cloud Director converts physical resource such as network, storage, and compute within a data center into elastic Provider Virtual Data Centers (pVDC). Cloud Providers can assign or share resources from a pVDC to one-to-many Organization VDCs (org VDC) for customers, thereby allowing for tiering of services to differing customers and units within a customer.

Cloud Providers typically, as a value-added service, provide access to catalogs of secure and patched OS builds and applications which a customer can then consume via self-service. Equally, a provider can allow a customer to upload their own builds and applications to catalogs should they wish. This becomes the foundation of a managed service that many Cloud Providers use as a jump point to more services. Control of the services and access to VMware Cloud Director services are controlled by permitting services and policy controls within a service to apply pre-determined limits on users.

## How can you consume Cloud Director?

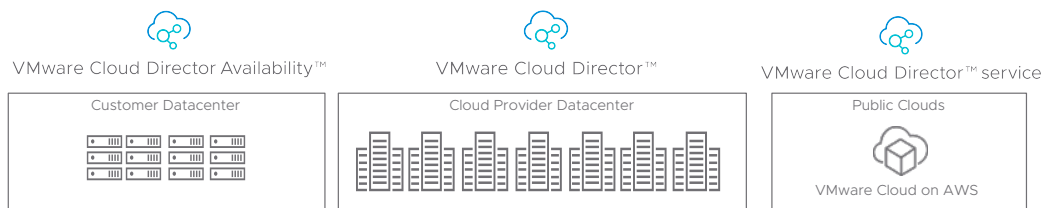

### Asset Heavy

VMware Cloud Director has been available to Cloud Providers to run in their data center since its inception in 2010. It has gone through considerable changes since that point but has always maintained an ‘in data center’ footprint. Cloud Providers all now have access to VMware Cloud Director in the Core Flex 7-point bundle. This means that all Cloud Providers in the program are now already paying for VMware Cloud Director even if it is not used. You can also use VMware Cloud Director to manage into your customer VMware vCenter environments, providing a single access point to manage your customer services and connectivity.

### Asset Lite

Cloud Director SaaS version is called “VMware Cloud Director service”. This provides “the same constructs of multi-tenancy and security in an asset lite environment – i.e., no assets need to be purchased, run and operated in a provider data center. VMware Cloud Director service is the same code base as VMware Cloud Director and its functionality is the same as VMware Cloud Director on-premises (Providing the VMware Cloud SDDC endpoint being managed exposes the feature for use).

## Why do you need Cloud Director?

Are you experiencing any of the following symptoms?

- ⇒ Excessive discounting on services.
- ⇒ Hard to introduce new products to your portfolio.
- ⇒ Slow delivery of services.
- ⇒ Too many errors in manual delivery.
- ⇒ Challenges meeting a customer's agile demands.
- ⇒ No room to maneuver in existing contracts.

### How Cloud Director addresses efficiency

All Cloud Providers using VMware Cloud Director today report operational improvements, better sales attach rates, and have been able to scale considerably without increasing operational costs. VMware Cloud Director automates a large proportion of the manual stages involved in delivering a service. Automation of existing operational scripts into a proper workflow system with VMware vRealize Orchestrator (a core component of VMware Cloud Director) allows operational task delegation to lesser skilled & expensive resources.

**51% Faster** to deliver compute,  
**31% more efficient** IT Infrastructure,  
**54% faster** to delivery new network capability  
(IDC, 2020) with VMware Cloud Director

Included in VMware Cloud Director is a full IP allocation system recording IP usage and automating the delivery of all necessary virtual resources to the service. Security, whether Edge perimeter based or per VM (micro segmentation), is managed and maintained via dynamic group or individual policies that can be highly automated to ensure compliance is maintained and allows the customers to focus on their business not their security.

VMware Cloud Director is an extensible platform and with the HTML5 framework, additional plugins can be deployed easily. The Tenant App is such a plugin, which provides you and your tenants with access to performance and billing dashboards that you, as a provider, can condition to each tenant's needs. If you permit it, customers can see their usage and a large volume of other metrics available from VMware vRealize Operations from within VMware Cloud Director, easing troubleshooting and providing visibility to their cloud services.

Most customers have a need for a certain level of control on their organization, whether read only view or full administration. Above vCenter and VMware vSphere, VMware Cloud Director and VMware Cloud Director service provide self-service and additional/ extensible services like networking and security from VMware NSX-T, which is now available in Cloud Director 10.2, plus Backup and Disaster Recovery from Cloud Director Availability, without impacting other customers.

Customers have varying needs, and some vary dramatically over a duration, typically these are met with manual additional resource configuration to meet their needs for a period. VMware Cloud Director can now offload this manual effort and provide autoscaling for Virtual Machines (subject to the application supporting it). This provides significant efficiency gains, both for the customer who gains confidence the resources will be available for the application only when needed, but also the provider, offering this as a service needn't worry about any further manual configurations.

### How Cloud Director addresses increasing revenue

Over a contract term, the faster you can get a customer to consume your services, the faster you get to revenue, and this makes a large difference to gross revenue over a contract. Onboarding faster and more effectively using the native Disaster Recovery and Migration as a Service solution – VMware Cloud Director Availability – puts self-service onboarding into the customer’s hands or provides a managed service for you to sell. With layer 2 configuration capability built in VMware Cloud Director Availability, now customers can migrate with less time delays and ensure confidence in application migration stability, driving faster time to revenue for cloud consumption.

Building your own services is a time consuming and complex task. Integrating different operational systems, different permissions, different capabilities etc. can often led to re-skilling and more orchestration. VMware Cloud Director and VMware Cloud Director service provide IaaS and other services out of the box, via an extensible plugin architecture. Many are fully integrated to look and feel just like VMware Cloud Director itself, so your customers needn’t reskill: everything is all in an interface they know already.

**32% higher annual revenue with services supported by VMware Cloud Director**  
(IDC, 2020) with VMware Cloud Director

Often building a cloud is a time-consuming task, months of architecting, complex inter-operability, and custom work, which denies valuable revenue. Well, no more! VMware Validated Designs make cloud simple, and with VMware Cloud Director VMware Validated Design for Cloud Providers, a lot of the heavy lifting is done for you already.

Now VMware Cloud Director with VMware Cloud Foundation on VxRail, VMware Cloud Director can easily stand up a cloud quickly and simply, drastically reducing the time to revenue and supporting a consumption model at the hardware and software layers with built in lifecycle management included. VMware Cloud Director has also got a whole lot simpler to deploy. A lot of development has gone into a whole new deployment UI which provides simplified workflow for different deployment types.

You can also increase revenue by decreasing the cost to deliver the service, if you are saving on operational costs already using VMware Cloud Director, where else do you save?

Typically, most customers are familiar with host-based services, but cloud changes this, and there are many optimizations to be made using a secure shared infrastructure, i.e. cloud economics. However, an ever-increasing demand in pay-as-you-go and “consumption-based pricing requires the provider to share the risk of underutilization” (451 Research, Cloud Transformation & Managed Services: 2020). Of course, much of the benefit in sharing infrastructure can then be passed on to the customer, but providers need to manage performance and SLA. VMware Cloud Director and NSX-T services provide logical segmentation of tenants, distributed firewalling (micro segmentation), distributed firewall dynamic membership, protecting and isolating every workload, whether a VM or a container. Storage IOPS policies and existing compute flex policies allow providers to avoid noisy neighbor issues, often associated with public cloud. And the Cloud Director Tenant App’s integration with vRealize Operations delivers all the appropriate compute management the provider needs to manage the service and provide tenants with access to dashboard views of their service and costs.



Integration with NSX-T in VMware Cloud Director is a game changer. Not only are there huge benefits from deploying NSX virtualized networking and appliances, saving hardware costs and vendor licensing costs. There are huge new security offerings, and security is the number 1 buyer requirement (IDC: U.S. Buyer Requirements for Managed Cloud Services and Expectations of Managed SPs Feb 2020). NSX-T and VMware Cloud Director provide dynamic policy driven and – importantly – hybrid security, addressing the real need for customers to use multiple clouds securely. This is especially important when you consider 2018 saw a 424% increase in data breaches due to cloud misconfigurations caused by human error. Going forward, 99% of all firewall breaches will be caused by misconfigurations, not flaws.

Did you know that using NSX-T distributed firewalling, whether layer 4 or layer 7, will offload considerable edge network traffic, and by routing on the ESXi hypervisor, it makes inter-application traffic more efficient, faster, and more secure, wherever the application moves? With multi-cloud, it is now practical and feasible to move workloads between clouds, but it

is critical that these placement changes do not weaken security, and the only way to ensure this is by using distributed firewalling and dynamic membership using static or dynamic characteristics including tags.

#### How Cloud Director addresses differentiation

Analyst research (451 Research Cloud Price Index 2020) has shown that Cloud customers will shop around and will not remain loyal to Cloud Providers who do not have a rich breadth of services. Simply put, customers do not see value in paying for services that are broadly equivalent between providers. This means certain services that are almost a commodity can see excessive discounting and customer attrition. To avoid this, Cloud Providers must differentiate their portfolio.

Do your customers have developers who are looking at public cloud services? This can be a risky approach given the proliferation of unvalidated open-source applications and the very granular charging of public cloud developer services. VMware Cloud Director provides improved application platform as a service capability with App Launchpad. Tenants can self-serve a curated list of services and applications including those from Bitnami marketplace, 3<sup>rd</sup> party and custom applications, those based on VMs, vApps and now containers using Helm charts. The zero-cost inclusive integration to the VMware Cloud Marketplace and Bitnami provides securely tested and validated applications, the former a diverse set of 3<sup>rd</sup> party applications, all of which can be set to auto-sync to gain the latest and greatest instances released, keeping customers safe and providing choice. The result is the delivery of application PaaS services, and increased consumption as there is no need to understand underlying infrastructure or security, this already handled.

Now Kubernetes cluster services can be delivered from within VMware Cloud Director for native Kubernetes and Tanzu Kubernetes Grid Multi-cloud (TKGm) (deploy on vSphere only) and vSphere (TKGs) all fully isolated and segregated with NSX-v and NSX-T (NSX-T is needed for TKGs). Now you can deliver a full circle solution; a dev ready cloud and a target platform to run the resulting container apps. In summary, this means Cloud Providers with VMware Cloud Director can now not only address developer personas, but also PaaS services and provide the guardrails to keep the application within a securely scalable and safe VMware cloud.

Cloud Providers need to ensure the customer experience is a good one, and VMware Cloud Director allows Cloud Providers to brand and theme the UI to their branding. This is simply achieved and sustainable to deliver your services to your customers, and with extensibility (whether a context menu or an iframe) it's a one stop shop where you can publish VMware Cloud services, 3<sup>rd</sup> party services and your own services with additional customization available for the entire user experience.

3<sup>rd</sup> Party solutions and your own solutions can be included in the UI of VMware Cloud Director through the extensibility framework, offered as a part of the solution at no additional cost. These can be made to look and feel like the existing platform so, again, tenants have a seamless experience. But importantly, they can be whitelisted and made available to tenants in a simple dropdown menu when they purchase the additional service from the Cloud Provider. Many of the newest services available in Cloud Director use this framework, plus container services (with TKGm and Kubernetes native), Object Storage services and the new Autoscaling plugin. In VMware Cloud Director, we have expanded our S3 Object Storage solutions to cover not only Cloudian and Dell ECS, but now native AWS S3, so tenants can consume storage services using their own AWS S3 accounts with their Virtual Data Center in VMware Cloud Director.

The VMware Cloud Director family of services is unique. There is no other platform that delivers so much service relevance to cloud consumers within your data center. Tenants can easily start on an IaaS service, either full pay as you go public cloud, reserved allocations of private cloud or dedicated allocation or host based private cloud, centrally controlled and full self-service should you wish to provide it. Ancillary to this, there are simple cross sell services like Disaster Recovery replication provided by Cloud Director Availability, elasticity to other data center resource pools such as those in VMC on AWS under the control of VMware Cloud Director service, or within your other data centers. Tenants needn't jump into different systems, Cloud Director can associate with other Cloud Director instances, meaning a simpler access for tenants to geographically dispersed resources. These simple services, in conjunction with on-premises capabilities to manage a tenant in-situ whilst managing seamless self-service onboarding to cloud, are the reasons tenants and providers love Cloud Director.

From a tenant perspective, the offering can be vastly differentiated. Depending on the access you provide, the consumption models you support and of course the surrounding managed or professional services you supply. Beyond the initial service in VMware Cloud Director of a Virtual Data Center (VDC) you can supply additional Edge virtualization self-service appliances, software defined NSX Advanced load balancer, Edge firewalling, IP services such as public IP and NAT services.

Unique value-added services for complete secure clouds, such as Layer 4 and Layer 7 Distributed Firewalling, and Storage VM encryption, FIPS support and VPAT are also available with VMware Cloud Director and NSX-T to help differentiate. Of course, lots of customers wish to have managed services in addition to self-service, VMware Cloud Director provides significant capability in this area too. You can take on managing the customer with the capabilities provided natively in the solution stack, such as Web Application Firewall and container ingress services with NSX Advanced load balancer, advanced networking services such as EVPN, differing pod offerings for CPU or RAM intensive offerings, managed Disaster Recovery testing with VMware Cloud Director Availability and managed reporting with vRealize Operations, and much more.

Ancillary services like monitoring and reporting via the VMware Cloud Director Tenant App dashboards, provide the tenant with out-of-the box VDC reports or managed service unique reports of their organization's services performance (collected with the latest vRealize Operations) and can also provide visibility of metered cost chargeback, configured and integrated into the UI for tenants providing a seamless user experience.

### How Cloud Director addresses risk reduction

Risk is expected in all businesses. How a business deals with risk is important, especially when you are a provider of services. Most Cloud Providers deliver services with a lot of operational overhead due to their existing tools not being integrated, and because they typically use outdated, manual processes that expose risk.

There is an 80-20 rule to consider. You could create your own DIY solution (we have seen examples of many times in Cloud Providers costing well over 1\$m), but it will become quickly out of date and require constant operational cost to manage and improve. Or you can utilize off the shelf software such as VMware Cloud Director, get 80% of what you need out of the box and use the supported extensibility framework to provide the other 20% you need (if at all). Using the new public APIs in offerings such as Container Services and App Launchpad, you can further minimize risk, programmatically driving most tenant and service provider functions. VMware Cloud Director is an API-first product, and although there is a lot of UI, it is self-consuming, and all the ancillary services from Container Service Extension, Object Storage Extension and App Launchpad, API is central to allowing providers to programmatically reduce risk and deliver touchless services if required.

Of course, it doesn't stop there, many of these APIs can be provided to tenants, such as the vCloud Director Terraform Provider which, as an open-source project, is simple for a tenant to use and for a provider to offer, delivering infrastructure as code services, pulling through more consumption, and driving down risk of misconfigurations.

However, risk is inherited in any Cloud. Simply put, as a customer, running your business on someone else's hardware is a risk, and you are at risk all the time from malware and security vulnerabilities. For a Cloud Provider to run in an asset light model with Hyperscale providers or VMC on AWS and VMware Cloud Director service, naturally this presents a tradeoff between the risk of outsourcing the hardware infrastructure to someone else, which decreases your control and flexibility vs. the cost of doing it yourself – 'build-or-buy'. In risk management, there is always a tradeoff. However, being able to have a Service Level Agreement such as is offered today in VMC on AWS and with VMware Cloud Director, your risk profile is alleviated somewhat; however, security is still your responsibility. With NSX-T and NSX-V, which is integrated into VMware Cloud Director and VMware Cloud Director service (NSX-T only) you can up-level your security to recognize threats, and then action policies to mitigate them as much as possible. VMware Cloud Director supports Edge firewall services and vAPP firewalls as well as Dynamic group membership micro segmentation firewalling and NAT to allow or deny north south and east west traffic.

In addition, with VMware Cloud Director Availability you can restore from older snapshots or failover, if necessary, to recover from security-related breaches. Risk may also be obvious in cost. For example, in some areas of the world, cheaper labor means the cost of outsourcing is not effective and doesn't make financial sense.

Many customers need high availability configurations and need to use Microsoft Clustering Services to reduce the risk of downtime. VMware Cloud Director supports independent disks via the UI, whereas before this was API only. Now, an independent disk can be attached to multiple VMs at the same time, allowing cloud providers to offer self-create cluster solutions such as Microsoft Cluster, Veritas Cluster, etc. on their VDC service. These independent disks have other benefits when used in the Container Service Extension. They can be used to provide persistent volume resources in Kubernetes (storage resources in a cluster that operate like a cluster resource and pods can request specific levels of resource from the node).

Risk is also something that can be invisible to infrastructure. Most customers are heavily outsourced to cloud (73% of customers make cloud their first choice\*), whether that be various off-premises clouds, Cloud Provider SaaS, IaaS or hosted

private clouds, and these environments are now considered critical in the modernizing/transforming journey to cloud. However, in the customers' desire to run rather than walk, most are encountering cloud skills gaps (90% report skill shortage\*). Cloud Providers are critical to these customer journeys and are equally susceptible to this skill gap, albeit sometimes less so. Risk is mitigated in having a platform that covers multi and hybrid cloud solutions, covering core pillars like security. The multi-site associations VMware Cloud Director can manage means your customers can access their Virtual Data Center resources in any cloud managed by the provider. This means potentially on-premises, in your data center(s) and in VMware Cloud Director service instances in VMware Cloud on AWS or other support public cloud providers. VMware Cloud Director spans multi-cloud, and with containers (95% of new applications use containers\*), multi-level infrastructure with security and isolation built in. Cloud Providers can hence focus on delivery and working with the customer on their cloud transformation.

\* 451 - Cloud Transformation & Managed Services: 2020, Melanie Posey and Owen Rogers 4 FEBRUARY 2020

### But, why now?

The world has changed in 2020, considerably so. The business world is investing more than ever in digital services to support the now distributed workforce, supply chain and new go-to-market services. This is primarily so that businesses can survive the economic slowdown and return to growth without huge business impact. We have seen over the last years the results of 'all into public cloud customer strategies' and now is not the time to be pushing harder on these efforts into alternative hypervisor-based clouds. Now is the time to move to cloud, but cloud based on the current and predominant hypervisor, vSphere. Investing now to help flatten the curve is as important for the cloud provider suppliers as it is for the consuming businesses, if not more so as the demand surges on cloud providers, automation is a necessity, not optional.

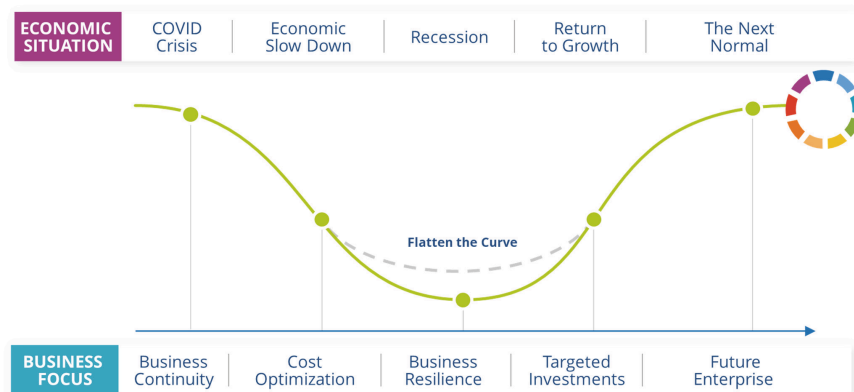

Source IDC:2020

Utilizing VMware Cloud Director, cloud providers can deliver economies of scale to their tenants, multi-tenancy, single point of control and access to services, whilst uplifting their security from edge to distributed for all assets. According to 451 Research "cost reductions are likely to be tied to a particular technology change – say the introduction of a new processor with better price/performance, or a new class of storage" (The Old Managed Service and The Sea: Cloud Economics Trends in 2020, Owen Rogers). VMware Cloud Director allows this differentiation using Flex Policies (see below), differentiated t-shirt or VM slicing for resources, or settings against a tenant Virtual Data Center, and in addition, VMware Cloud Director brings in Storage IOPS controls and tiering to tenants. This capability to centralize and deliver highly automated and differentiated services will provide optimization to customers as they are onboarding critical workloads and services into providers. Even if security and requirements dictate a hosted customer private cloud in the cloud provider data center, this can still be accessed and managed via VMware Cloud Director.

More detail on how this works can be found in this [whitepaper](#):



[vmware.com/content/dam/digitalmarketing/vmware/en/pdf/vcat/architecting-multi-site-vmware-vcloud-director.pdf](https://vmware.com/content/dam/digitalmarketing/vmware/en/pdf/vcat/architecting-multi-site-vmware-vcloud-director.pdf)

Essential choices for tenants; “Best Execution Venue (BEV) strategies center on the notion that every class of IT-related business need has an environment where it will best balance performance and cost, and the IT organization should be able to select that environment as part of the general practice of IT.”

Source: The old managed service and the sea: cloud economics trends in 2020, Owen Rogers

Essentially VMware Cloud Director helps deliver customer BEV choice through consumption models, offering optimized controls at each component; compute, storage, network, and security, but goes a step further. Consumption modelling and placement control help solve BEV challenges and are explained below, but what about consideration to resources needed for applications beyond the basic infrastructures (‘the what’) such as applications. VMware Cloud Director’s hybrid control across multiple clouds means tenants can also control ‘the where’ applications need to reside to optimally use other cloud resources. Cloud Providers can design pods specific to application or resource requirements and offer these as targets for their tenants, allowing for complete diversity and control. VMware Cloud Director service on VMware Cloud on AWS is a great example of BEV choice, providing essential AWS adjacency for services to a VMware Infrastructure and application service.

Most Cloud Providers have redundant and distributed data center architectures which service many customers. From an aggregated viewpoint, having a single point of entry and single point of administration is required to alleviate operational cost and increase speed of delivery. It’s not so simple to simply ‘stretch’ management across more than 2 locations, With the VMware Cloud Director service SAAS solution, providers can also now have an additional vCenter and SDDC in VMC on AWS data centers, allowing for stretch management.

## How does VMware Cloud Director address customer consumption?

### vApp for packaging application infrastructure

Cloud Director can service customer requirements for infrastructure based on Virtual Machines, containers and introduces the concept of a vApp. A vApp is a preconfigured virtual machine that packages applications and parameters that define operational details. A vApp packages applications with their required operating systems, allowing disparate virtual machines to work together in a stack as an application, including storage, networking and security provided by edge services whether on NSX-V or NSX-T.

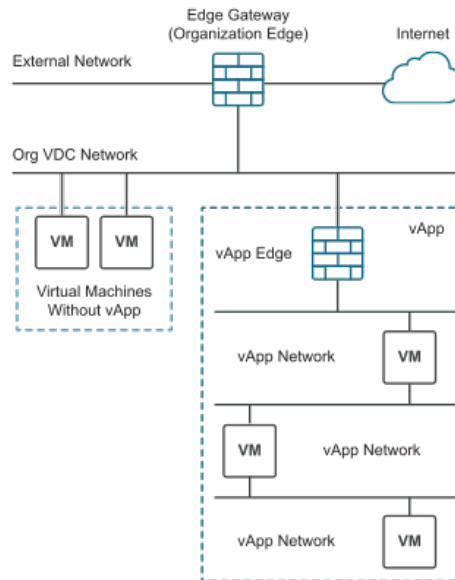

This is a great facility for whole application deployments, test, development, and production architectures to be built and consumed quickly and effectively.

VMware Cloud Director supports different models of consumption of your physical data center resources to be divided up and provided to customers utilizing the following mechanisms.

#### Pay-As-You-Go cloud

Pay-as-you-go is an on-demand service to tenants with no up-front resource allocation to their Org VDC and uses a VM resource allocation. This provides a true public cloud experience to your customers and is great for transient workloads such as development and QA environments. In this service, you can over-provision physical resources with a percentage of non-guaranteed capacity reflected in your SLAs.

As this is set at a VM level, CPU quota, CPU guarantee and speed, as well as memory quota and guarantee, are applied on a per VM basis and not at resource pool level. To avoid oversubscribing your entire pool, you can set a maximum per VM or number of Pay-as-you-go VMs in the Org VDC.

#### Allocation pool of resources

This is typically the most used model among Cloud Providers as it allows allocated resources but also guarantees some percentage of resources for unexpected peaks in requirement. An allocation pool is where only a percentage of allocated resources are allocated as a committed reservation to the Org VDC. This is ideal for stable production workloads that need guaranteed resources and provides percentage burst capacity into non-guaranteed resource pools. This makes a predictable cost model for customers and lowers risk of a VM not being able to start due to resource constraints, hence suitable for guarantees and SLA.

These allocations translate into vSphere limits set on the resource pool and are based on CPU and Memory as a first come first serve basis for VMs only as they are powered on. If another organization VDC is using more resources, there is no guarantee that resources will be available to power on VMs. So, underlying availability of resource is must, not only to power on VMs but also guarantee reservation to VMs.

#### Reservation Pools of resources

Whilst the Pay-as-you-go and Allocation resource pools are quite complex to manage, the reservation is much simpler. A reservation pool is reserved i.e., it's a 100% committed allocation of resources, even if none are turned on to use the resources. The Reservation and Limit for CPU and Memory are set to be equal to the allocation value set on the Org.

This model is typically more expensive for the customer and could lead to much underutilized resource, but guarantees capacity, which is ideal for business-critical applications.

**Flex Allocation model**

Using a combination of a flex allocation VDC and VDC compute policies, the amount of CPU and RAM at both the VDC and the individual virtual machine (VM) level can be managed. Many providers roll this into 't-shirt sizing' of VM services. This provides either an elastic pool or elastic VMs with additional control of storage and network.

Of course, once you have selected resource allocation models, you don't have to do anything more in vCenter, this is automated for you using vSphere reservations and limits.

**VMware Cloud Director extensibility**

Most platforms require some sort of extensibility to allow you to personalize the service and to integrate it with business systems. Cloud Director provides extensibility in 2 ways: UI extensibility and operation orchestration. UI extensibility uses a supported framework in VMware Cloud Director, delivering a huge amount of value and capability separated to the core product. As the diagram shows there are many services ancillary to core VMware Cloud Director services that can be fully automated and delivered to provide tenants with a seamless experience.

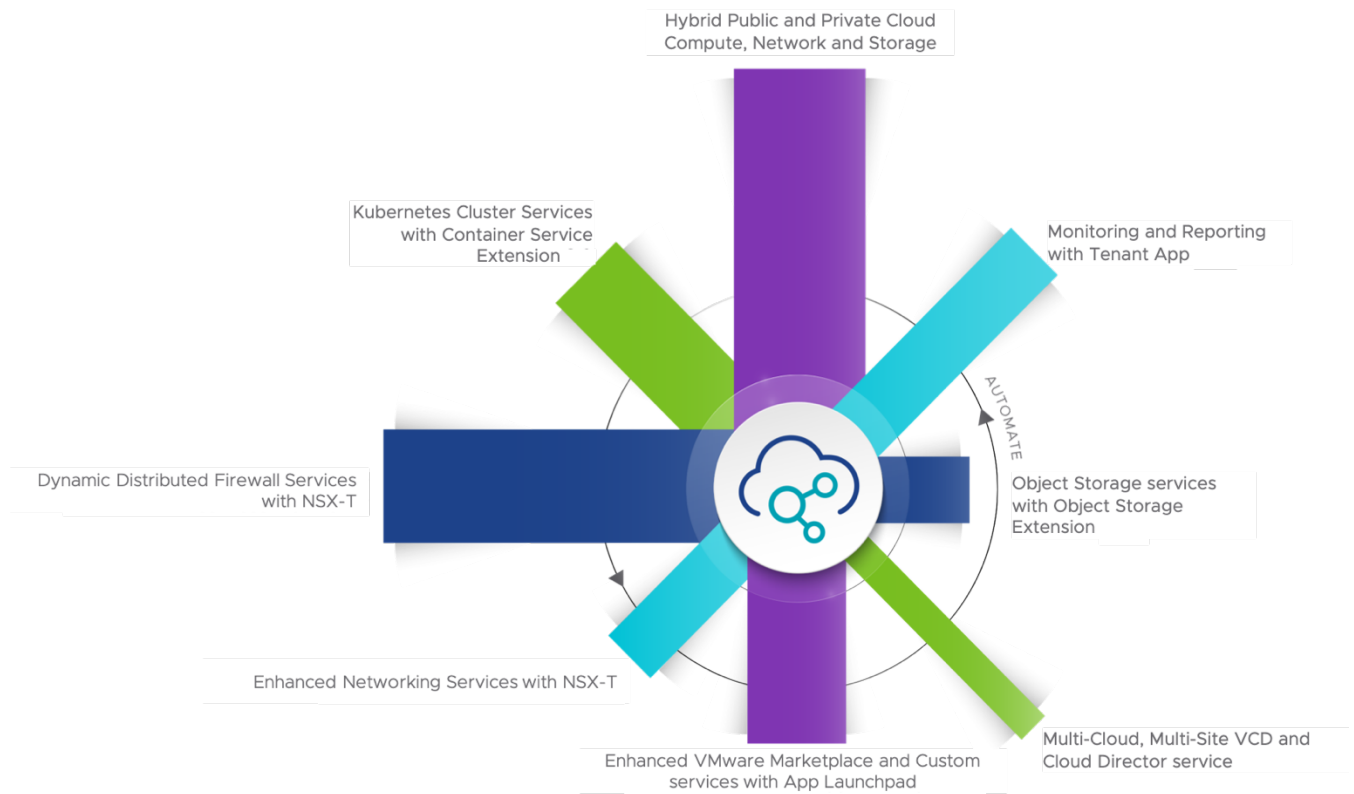

**UI extensibility for VMware Cloud Director**

Portfolio extension is a major factor to keep customers engaged and so you can provide the best service you can. Analyst research has shown that Cloud Providers with a richer portfolio of solutions are able to charge more and see less discounting and customer attrition. There are several factors at work here: differentiation and breadth. The more you can differentiate and provide a good breadth of services, not just with managed services but also with self-service portfolios, the less likely a customer will need to go anywhere else.

The Cloud Director extensibility framework is an open-source capability that provides differentiated solutions such as Disaster Recovery, Migration, Backup and Restore, and Object Storage (not a limited list). Some of these solutions are not

from VMware but are using the extensibility framework to push solution capabilities directly into Cloud Director for customers to consume. There are two different levels of extensibility: basic UI extensibility, and advanced. Basic will literally pull the application itself, colors, branding and all, into Cloud Director UI. If the application has a proficient API, you can alternatively opt for an advanced extensibility, pull in the functions via the API to make it look and feel like a Cloud Director natural extension like in the following examples:

#### Disaster Recovery from VMware Cloud Director Availability

A great example of UI extensibility is Cloud Director Availability. Using the Cloud Director extensibility framework, VMware has created a Disaster Recovery and Migration solution that is simple and quick to deploy in your Cloud Director and Cloud Director service environment. Within hours, you can configure customers to replicate either protection or migration into their target VDC, whether in your premises or hosted in VMware Cloud on AWS under Cloud Director service's control (Migration only). Once in their Org VDC you can sell Cloud to Cloud Disaster Recovery between your data centers.

#### Dell Data Protection for VMware Cloud Director

Data Protection is a core requirement for workloads in cloud, but previously there has been no native solution for Cloud Director clouds. Now Cloud Providers can deliver full self-service backups and restores directly to the Cloud Director interface for their tenants.

Dell EMC Data Protection for Cloud Director is great example of a plug-in providing tenants with a single management endpoint for backup and restore operations in their virtual data centers. Tenants can manage crash-consistent image-level backups of VMs, vAPPs and files, restore to a new VM or in-place, by policy or ad hoc and even file-level restore.

#### S3 Object Storage via Object Storage Extension

Proving how versatile the extensibility framework is, the Cloud Director Object Storage Extension (vOSE) provides an S3 interface to Cloud Director. The plugin extension allows Cloud Director and organization cloud administrators to view, configure and perform other management tasks, with VMware Cloud Director, this is now OSE and has had substantial updates in capability. The OSE provides S3 Object Storage capabilities with Cloudian's HyperStore S3 object storage and Dell ECS within Cloud Director and AWS native S3 as well as Ceph. Tenant portals can be offered to provide customers with self-service access to configure and manage their own S3 Object Storage buckets as storage targets. This capability includes the S3 Object Lock security solution that prevents malware from changing any files.

#### Kubernetes Cluster Services and the Container Service Extension

Within VMware Cloud Director Kubernetes is a first-class citizen, this means Kubernetes infrastructure is as native to VMware Cloud Director as a VM or vAPP. The Container Service Extension (CSE) plugin provides enhanced support in the plugin UI, API and CLI for ecosystem Kubernetes Clusters, such as native Kubernetes and also Tanzu Kubernetes Grid Multi-cloud (TKGm). Tanzu Kubernetes Grid vSphere (TKGs) is supported natively and isolated with NSX-V & T for multi-tenancy, it does not need CSE to deliver operations, and updates with new VMware or custom templates. As more cloud workloads continue to 'transform' to cloud native architectures, more and more customers require Cloud Providers to provide a secure environment for their cloud services to run on. Typically, container solutions run in VMs and are hence bound by the same management capabilities at the VM level, which means many operational processes are still very relevant in these environments. Now Tanzu Kubernetes Grid TKGs and Tanzu Basic brings container solutions and full stack to vSphere and VMware Cloud Director, allowing Cloud Providers to accelerate their Kubernetes Clustering solutions and controls for their customers moving away from a VM analog to a native container on ESXi strategy for speed and simplicity.

VMware has focused on Cloud Director as the entry point for customers to access cloud native solutions for their developers. This is complimented with an array of Cloud Native solutions mostly derived from the Container Service Extension (CSE) API work that allows developers to create and operate Kubernetes clusters via their normal KubeCTL commands. CSE delivers support for differing Kubernetes solutions, native on Enterprise PKS, and with Essential PKS clusters in the Cloud Director UI. This unified user experience is agnostic to the backend, whether CSE performs the K8s cluster L/C work or vSphere Tanzu Basic does instead, the UI experience remains the same.

However, Kubernetes by itself is only one layer in the container service stack. Other capabilities from the container ecosystem are needed as well, such as a code repository, cluster health monitoring and healing, and lifecycle management.

If a developer wants to use their own tools and just wants Kubernetes, then VMware Cloud Director with CSE or Tanzu Basic (TKGs or TKGm) this is a great solution to enable Cloud Providers to access and deliver upstream Kubernetes cluster

provisioning and management either via CSE or natively in VMware Cloud Director with vSphere Tanzu and differentiated with additional applications and tools from Bitnami via the App Launchpad.

#### Deliver Bitnami applications to your tenants

The Bitnami Community Catalog is fully integrated with VMware Cloud Director via the App Launchpad. This makes it easy for Cloud Providers' customers to find, deploy and manage software – across any physical or virtual environment, in any format (VM, container, and public cloud images), and for any cloud platform. With VMware Cloud Director integration and App Launchpad, Cloud Providers will be able to offer Bitnami, custom, and 3<sup>rd</sup> party application portfolios to developers within the VMware Cloud Director tenant portal. Developers then just point, click, and deploy the necessary framework applications they need operating in their tenant portal, which is easily provisioned by their DevOps teams.

The process to deliver applications to your end customers couldn't be easier. A simple MSP contract must be signed, allowing Cloud Providers access to the service, where they can subscribe to the Bitnami applications, once done, these are synchronized to the Cloud Director instance of your choice, where they are available for customers to click to deploy.

#### Provide your customer applications via App Launchpad

Need to present your tenants with access to applications rather than relying on their knowledge of the underlying infrastructure? The App Launchpad feature will permit tenants access to a pre-curated catalog of applications, defined by the cloud administrator that they can simply deploy with some integrated workflow and a 1-click app deployment. App Launchpad functionality is integrated with VMware Cloud Director and automates VM or container creation, networking, firewalling, and assigns a Public IP for the application without the user needing to have any knowledge of the underlying fabric.

#### Infrastructure as code with Terraform Provider

Terraform Provider enables VMware Cloud Director customers to access "Infrastructure as code," e.g., virtual infrastructure that can be built, modified and retired entirely by executing code and using the configuration file as the input. Providing infrastructure as code using Terraform Provider in VMware Cloud Director enables customers to manage, provision and orchestrate infrastructure resources.

As a Cloud Provider, you can create and configure this capability then use it for automating deployment of infrastructure and services to customers or offer it directly to tenants. Cloud Providers can configure a range of offerings using a standard configuration management service. Terraform Provider enables customers to provision VMware Cloud Director infrastructure and services or consume more advanced offerings to configure and orchestrate lifecycle management using additional custom plugins.

#### Operational Automation Extensibility within Cloud Director

To save operational costs, Cloud Director automation allows for scaling and repeating of processes to avoid errors and deliver repeatable business. Using vRealize Orchestrator (vRO), a core component of Cloud Director, Cloud Providers can import existing operational and production scripts, exposing vRO workflows as dynamic tiles in the Cloud Director HTML5 UI per tenant or for all tenants.

vRealize Orchestrator natively integrates into VMware Cloud Director, enabling cloud providers to automate complex workflows and deploy a variety of services such as ticketing, service queries and more, all while maintaining access control and visibility to the enterprise and Cloud Provider. Using this capability Cloud Providers can quickly and easily extend their portfolio to tenants with their own services and specialization.

## Delivering monitoring and chargeback to the customer

#### Monitoring

The VMware Cloud Director HTML5 UI, in combination with vRealize Operations Manager, vRealize Management Pack for VMware Cloud Director, and vRealize Management Pack for NSX, allows tenants to access a performance dashboard, along with reporting and billing capabilities from the drop-down menu within VMware Cloud Director. With the VMware Cloud Provider Flex core, vRealize Log insight is also included and can be used in combination with VMware Cloud Director and Cloud Director Availability to track syslog events.

### Chargeback

Inclusive metering and dashboard capabilities allow Cloud Providers to chargeback services to their tenants and to individual customers to review their billing data. Cloud Director chargeback is provided by Tenant App and provides visibility into virtual machine, App Launchpad services and Kubernetes service costs, chargeback accountability and performance dashboards in self-service. Cost transparency and accountability to understand actual cost of virtual infrastructure required to support business services.

The tenant app provides tenants with visibility into performance and billing/metering chargeback information, a critical feature in understanding usage and service quality. Tenant App also provides additional custom report capability whereby providers can extend their managed service and increase revenue with custom dashboards. This functionality is included in the base Flex core and requires vRealize Operations Manager.



VMware, Inc. 3401 Hillview Avenue Palo Alto CA 94304 USA Tel 877-486-9273 Fax 650-427-5001 [www.vmware.com](http://www.vmware.com).  
Copyright © 2021 VMware, Inc. All rights reserved. This product is protected by U.S. and international copyright and intellectual property laws. VMware products are covered by one or more patents listed at <http://www.vmware.com/go/patents>. VMware is a registered trademark or trademark of VMware, Inc. and its subsidiaries in the United States and other jurisdictions. All other marks and names mentioned herein may be trademarks of their respective companies. Item No: vmw-wp-temp-word 2/19