



Solutions for Pulp and Paper

A broad portfolio of technologies targeting the needs of paper chemical companies and formulators





Solutions with your needs and applications in mind

As a leading provider of process auxiliaries, intermediates and functional chemicals for the pulp and paper market, Dow can help you achieve the best balance of performance, processing efficiency, cost-in-use and energy savings for your applications.

Paper chemical companies and formulators around the globe have made Dow their supplier of choice because of our broad portfolio of technologies and industry leadership, combined with excellent application-oriented technical and regulatory support. Now, with the addition of silicones, we offer you an even wider range of chemistries and knowledge.

Our products enable efficient pulp processing and paper making, and they provide the foundation for achieving essential and evolving properties in pulp, paper and board products – such as whiteness and wet and dry strength – and for meeting critical industry needs and trends. These include biodegradability; enhanced environment, health and safety profiles; indirect food contact approvals; and greater energy efficiency.

At Dow, we're committed to working with you each step of the way to meet unique processing, performance and industry challenges. See how much Dow can do for you.

Solutions for Pulping

Bleaching and Washing:

Optimize bleaching efficiency, maximize brightness, and avoid formation of undesirable odors and flavors in food

Solutions:

VERSENE™ Chelating Agents – for sequestering heavy metal ions to minimize brightness reversion, prevent colored formations, and avoid undesirable flavors and odors

DOWSIL™ Silicone Antifoams – to prevent foam problems in sulfite and kraft stock washing that are effective at low use levels and help improve washing efficiency and drainage for cleaner pulp

DOWFAX™, ECOSURF™ and TERGITOL™ Specialty Surfactants – for antifoaming formulations and deaeration mixtures that improve drying time, enhance product integrity and increase process efficiency



Solutions for Paper Making

Deaeration, Debonding and Headbox Applications:

Formulation additives to help enhance product quality and process efficiency

Solutions:

TERGITOL™, TRITON™, ECOSURF™ and DOWFAX™ Specialty Surfactants – can be used in high-performance deaeration mixtures to help improve drying time and enhance product integrity

Amines and Quat 188 Cationic Reagent – critical components of optical brighteners and wet- and dry-strength resins

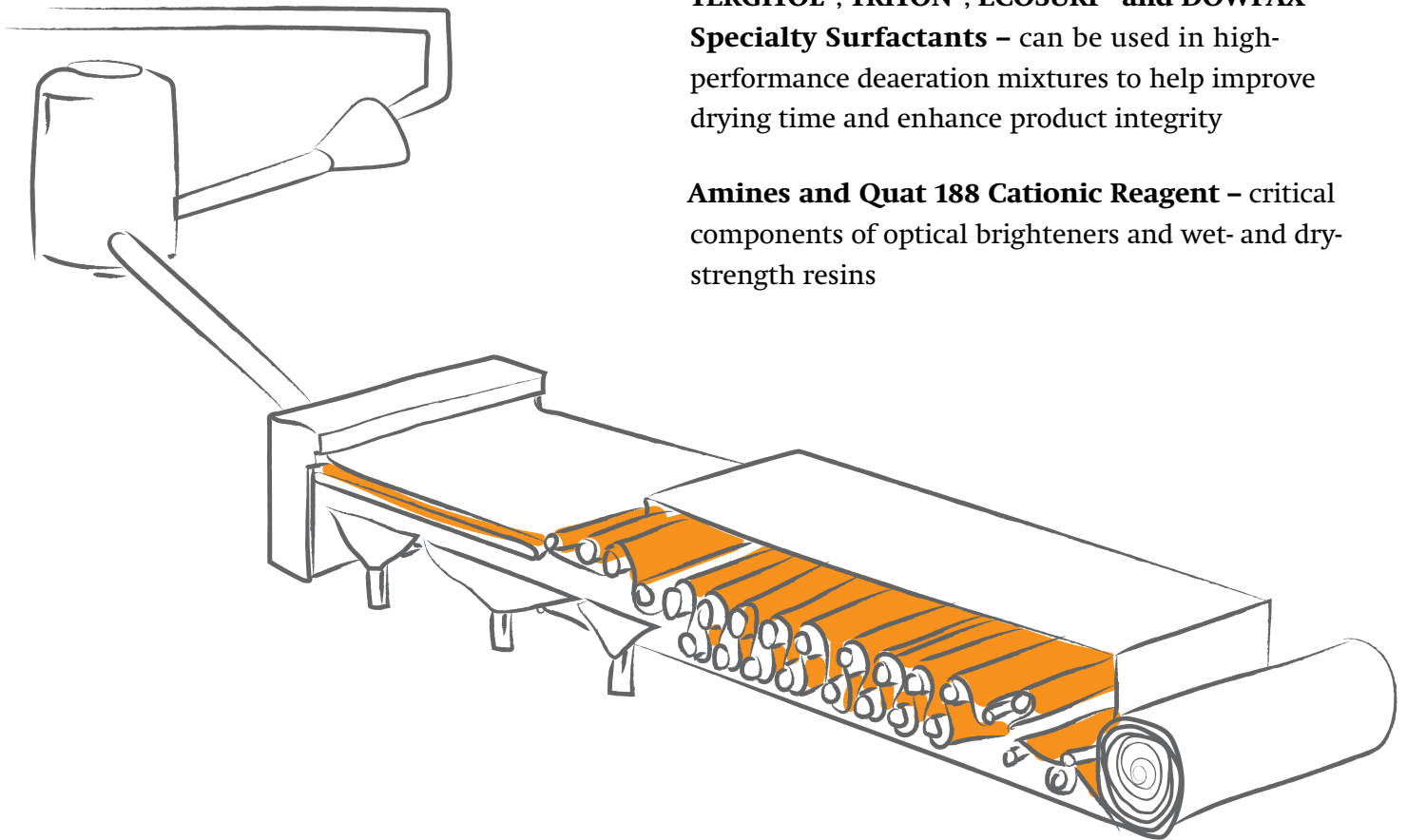

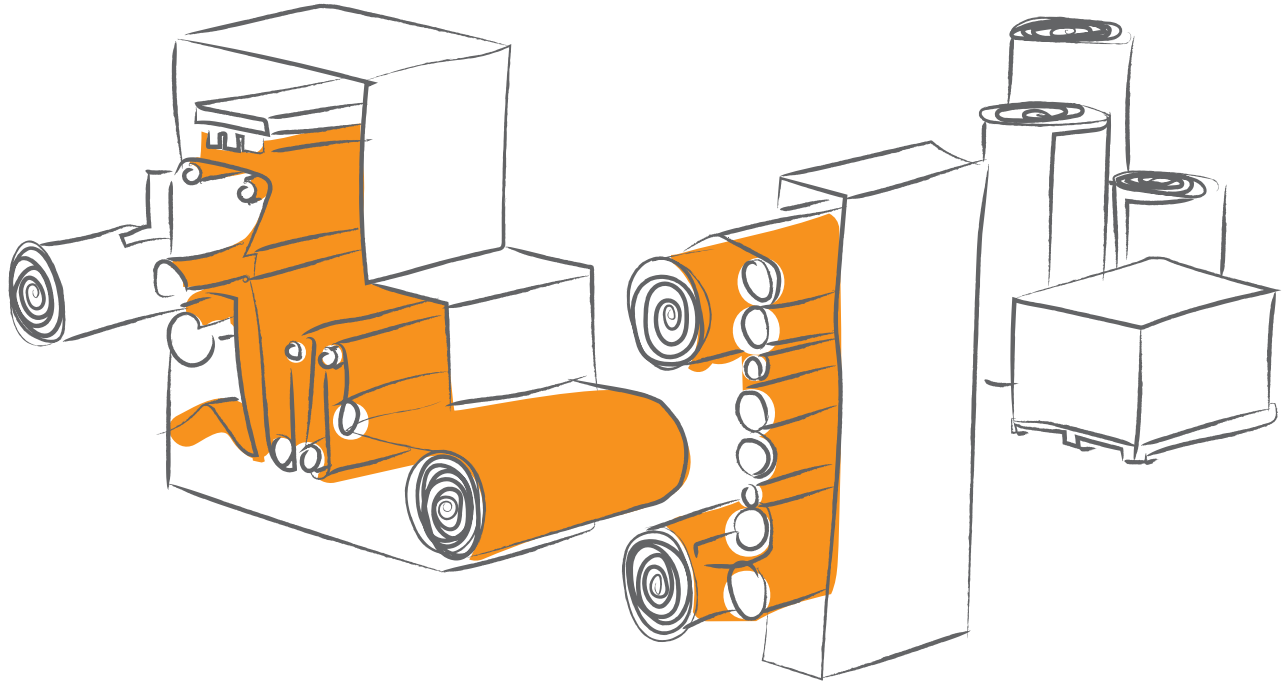

Solutions for Paper Finishing

Components for Fillers and Viscosity Modifiers:

Solutions for optimized finished quality

Solutions:

Amines – critical components for paper filler slurries

UCON™ Viscosity Modifier – increases permanence and offers a low-toxicity option for glue used in tissue applications

CARBOWAX™ Polyethylene Glycols – provide softening, flexibility and desirable slip characteristics while serving as an additive stabilizer to support consistent color and dimensional properties

Solutions for Recycling

Pulping and Deinking:

Solutions to help reduce waste and improve process efficiency

Solutions:

TERGITOL™, TRITON™, ECOSURF™ and DOWFAX™ Specialty Surfactants – help prevent redeposition of ink during the recycling process

DOWANOL™ Glycol Ethers – wide range of solvents that help remove ink particles from recycled paper

VERSENEX™ Chelating Agent – enhances cleaning and bleaching of recycled paper

DOWSIL™ Silicone Antifoams – help control foam during the pulping process when recycling paper

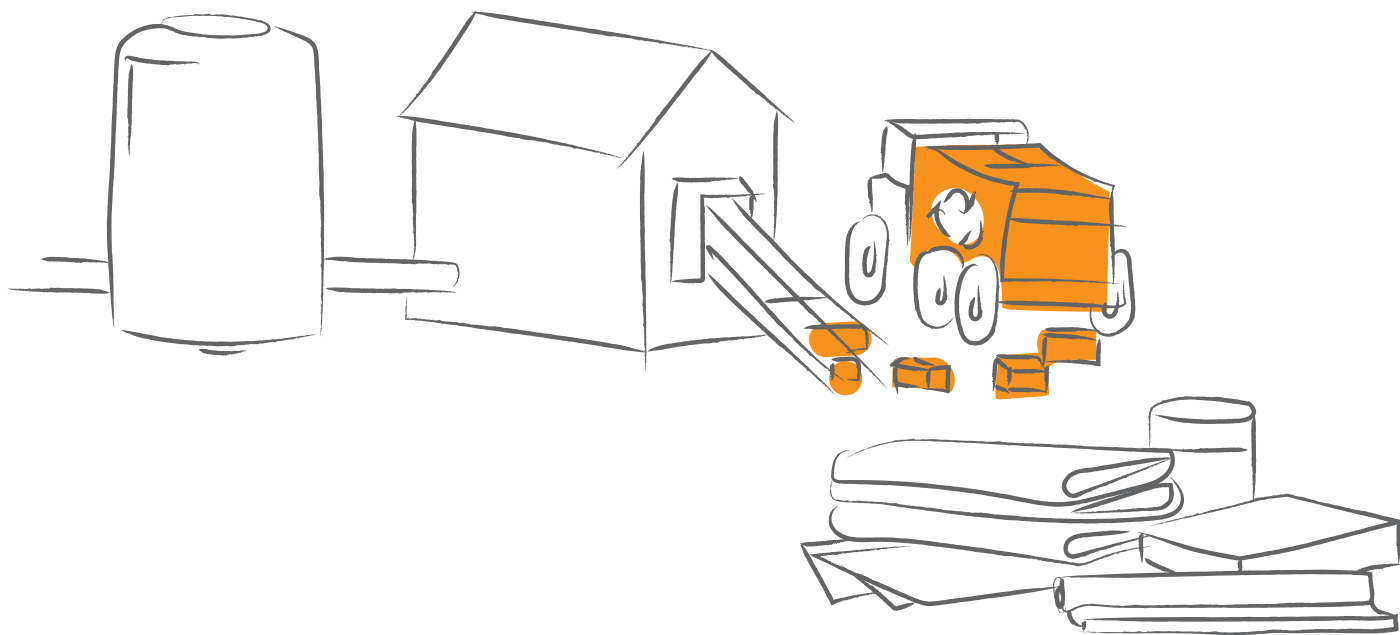



Commitment to the **Environment** and **Sustainability**

Dow is committed to **maintaining world-leading operations performance in natural resource efficiency, environment, health and safety.**

For decades, we have helped our customers across the paper industry – from pulp and paper manufacturing to pressure sensitive adhesion and release – operate more sustainably. This includes using product options and solutions that help to:

- Reduce solvent and processing-chemical requirements
- Reduce energy and processing-water requirements
- Improve productivity
- Improve worker safety
- Reduce waste
- Promote reuse and recycling



Contact Us
Today

Let's work together to meet your pulp and paper formulating needs. For more information on products, samples or technical assistance, connect with us at consumer.dow.com/pulp.

HANDLING PRECAUTIONS

PRODUCT SAFETY INFORMATION REQUIRED FOR SAFE USE IS NOT INCLUDED IN THIS DOCUMENT. BEFORE HANDLING, READ PRODUCT AND SAFETY DATA SHEETS AND CONTAINER LABELS FOR SAFE USE, PHYSICAL AND HEALTH HAZARD INFORMATION. THE SAFETY DATA SHEET IS AVAILABLE ON THE DOW WEBSITE AT WWW.DOW.COM, OR FROM YOUR DOW SALES APPLICATION ENGINEER, OR DISTRIBUTOR, OR BY CALLING DOW CUSTOMER SERVICE.

NOTICE: No freedom from infringement of any patent owned by Dow or others is to be inferred. Because use conditions and applicable laws may differ from one location to another and may change with time, Customer is responsible for determining whether products and the information in this document are appropriate for Customer's use and for ensuring that Customer's workplace and disposal practices are in compliance with applicable laws and other government enactments. The product shown in this literature may not be available for sale and/or available in all geographies where Dow is represented. The claims made may not have been approved for use in all countries. Dow assumes no obligation or liability for the information in this document. References to "Dow" or the "Company" mean the Dow legal entity selling the products to Customer unless otherwise expressly noted. **NO WARRANTIES ARE GIVEN; ALL IMPLIED WARRANTIES OF MERCHANTABILITY OR FITNESS FOR A PARTICULAR PURPOSE ARE EXPRESSLY EXCLUDED.**

®™ Trademark of The Dow Chemical Company ("Dow") or an affiliated company of Dow.

© 2018 The Dow Chemical Company. All rights reserved.

AGP15456

Form No. 26-2569-01