

HD

Tune in to Digital Convergence

DVB-SCENE

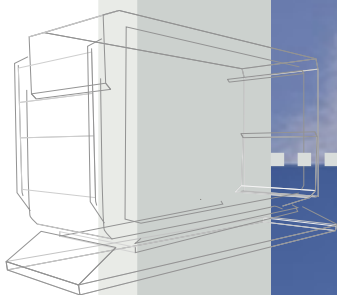

16

DVB®

The Standard for the Digital World

This issue's highlights

- > DVB-H et al.
- > DVB-H in L-Band or UHF?
- > IP Datacast over DVB-H
- > IPTV and DVB-IP
- > HD ready
- > CPCM update

HDTV KICK-OFF!

WORKING TOGETHER

A word from the DVB Project Office

Peter MacAvock, Executive Director



broadcast. Delegates from the Americas welcomed the opportunity to see DVB's terrestrial broadcast technology in action.

Brazil's CERTI Foundation was also on hand to demonstrate interactive applications that use the convergence of DVB-T and the mobile telecoms network to promote digital inclusion. CERTI developed these technologies through its membership of the EU's INSTINCT project. DVB was represented at the event by Eoghan O'Sullivan with support from a number of DVB member companies in the region.

Korea remains a key market for DVB technology, despite its choice of the ATSC terrestrial standard and the recent deployments of S-DMB and T-DMB handheld broadcasting services. DVB has just signed a Memorandum of Understanding (MoU) with the influential KOBETA organisation (the association of Korean broadcast television engineers). The MoU is designed to foster close links between DVB and KOBETA with a view to sharing experiences in the deployment of digital television and promoting harmonised worldwide standards. Finally, DVB has just launched a website dedicated to providing information on DVB-H technology and services around the world. The site promises to be the place where those interested in handheld broadcasting can find out all they need to know about the various ongoing trials and pilots, full service launches, product development, and much more. But to keep it up-to-date it relies on contributions from those in the industry: you.

Visit www.dvb-h-online.org.

The Project Office has been active representing DVB in the warmer climes of Costa Rica at the sixth meeting of the CITELE Permanent Consultative Committee II - the Inter-American Telecommunication Commission which coordinates regulatory policy in broadcasting and telecommunications in the Americas. DVB has just joined the organisation with a view to ensuring accurate representation of information on DVB standards and specifications and aiding with the deployment of

digital television in the region. We hosted a reception and a demonstration of the latest DVB-T and DVB-H technologies, using commercially available 6 MHz SD and HDTV receivers. The DVB-T demonstration consisted of the broadcast of one multiplex in a 6 MHz channel that included one HD service, one SD service and an information service, with a total data rate of 19.7 MBit/s. A DVB-H multiplex containing two services was also

NEW STANDARDS:

TS 102 819 V1.3.1 'Globally Executable MHP (GEM), including a packaged media target' (Published 28/10/05)

TR 102 377 V1.2.1 'Implementation guidelines for DVB handheld services' (11/05)

The views expressed in this newsletter are those of the individual DVB members or guests and are not necessarily the views of the DVB Project Office or Steering Board.

Published by the DVB Project Office,
c/o European Broadcasting Union,
17a Ancienne Route,
CH-1218 Grand Saconnex, Switzerland.
www.dvb.org & www.mhp.org

Editors: William Daly, Harold Bergin
Editorial and Advertising enquiries to: WHD PR
Email: news@whdpr.com
Telephone: +44 (0)20 7799 3100

All rights reserved. No part of this publication may be reproduced without prior consent of the publisher.
All content correct at time of printing.
© DVB-SCENE 2005.

DVB and MHP are registered trademarks of the DVB Project. Certain other product names, brand names and company names may be trademarks or designations of their respective owners.

To obtain extra copies of DVB Scene please contact Eoghan O'Sullivan at osullivan@dvb.org.
Delivery charges will apply.
Printed by Lithmark Limited.

DVB-H et al.

Ulrich Reimers – Chairman, DVB Technical Module

DVB-H (Digital Video Broadcasting - Transmission System for Handheld Terminals) is the latest development within the set of DVB transmission standards. The DVB-H technology is a spin-off of the DVB T standard. It is to a large extent compatible with DVB-T but takes into account the specific properties of typical terminals, which are expected to be small, lightweight, portable and – very importantly – battery powered. DVB-H can offer a downstream channel at high data rate which can be used standalone or as an enhancement of mobile telecommunications networks which many typical handheld terminals are able to access anyway. DVB-H thus creates a bridge between the classical broadcast systems and the world of cellular radio networks. The broadband, high capacity downstream channel provided by DVB-H features a total data rate of several Mbit/s and may be used

The term IP Datacast is used by DVB for the technical elements required to create DVB-H based services and those that are necessary to integrate DVB-H in a hybrid network structure consisting of both a mobile communications network such as GPRS or UMTS and an additional DVB-H downstream. IP Datacast supports various use cases – among them the broadcasting to terminals which do not support an interaction channel. The set of specifications for IP Datacast (phase1) was approved by DVB in October 2005.

In Japan, a system called ISDB-T (Integrated Services Digital Broadcasting Terrestrial) was developed taking DVB-T as a starting point. One feature that ISDB-T adds to DVB-T is the possibility of splitting the channel bandwidth into segments. The data rate which can be transmitted in one

“...can be used standalone or as an enhancement of mobile telecommunications networks...”

for audio and video streaming applications, file downloads and for many other kinds of services. The system thereby introduces new ways of distributing services to handheld terminals, offering greatly extended possibilities for content providers and network operators. DVB-H is a fully proven technical system which was carefully tested by the DVB-H Validation Task Force in the course of 2004. The results of these tests are publicly available as ETSI Technical Report TR 102 401.

segment is limited to approximately 400 kbit/s. Content requiring only such a limited data rate like audio or one video channel targeting small screens can be received on terminals with a narrow-band tuner thus reducing the power consumption of the tuner. ISDB-T is exclusively used in Japan.

T-DMB (Terrestrial Digital Media Broadcasting) and S-DMB (Satellite Digital Media Broadcasting) are Korean developments based on DAB (Digital Audio Broadcasting). The concepts behind T-DMB were generated in



Europe. A T-DMB channel (in Europe) has the same bandwidth as a DAB channel (1.5 MHz). Due to the introduction of additional forward error correction etc., the data rate available using DMB in that channel is approximately 1 Mbit/s.

FLO (Forward Link Only) is the brand name of a system developed by Qualcomm in the US. It is probably fair to say that FLO was developed as a response to DVB-H and is based on know-how gained by analysing the DVB-H technology. Qualcomm saw no reason to retain backwards compatibility to DVB-T and therefore changed system components accordingly. FLO is the ‘new kid on the block’. Documentation on the system is scarce. Performance figures quoted by Qualcomm indicate a performance similar to that of DVB-H with some advantages in required C/N. But how do you verify the performance of a proprietary system?

Neither ISDB-T nor T-DMB or S-DMB knows a concept similar to that of IP Datacast. MediaFLO is the service layer on top of FLO.

The diagram shows how Informa Telecoms and Media predicts the growth of ISDB-T, T-DMB and DVB-H markets between 2006 and 2010.

Prof. Dr.-Ing. Ulrich Reimers is the Managing Director of Institut fuer Nachrichtentechnik (Institute for Communications Technology) at Technische Universitaet Braunschweig (Braunschweig Technical University), Germany. He is one of the founders of the DVB Project and the chairman of the Technical Module of the DVB Project.

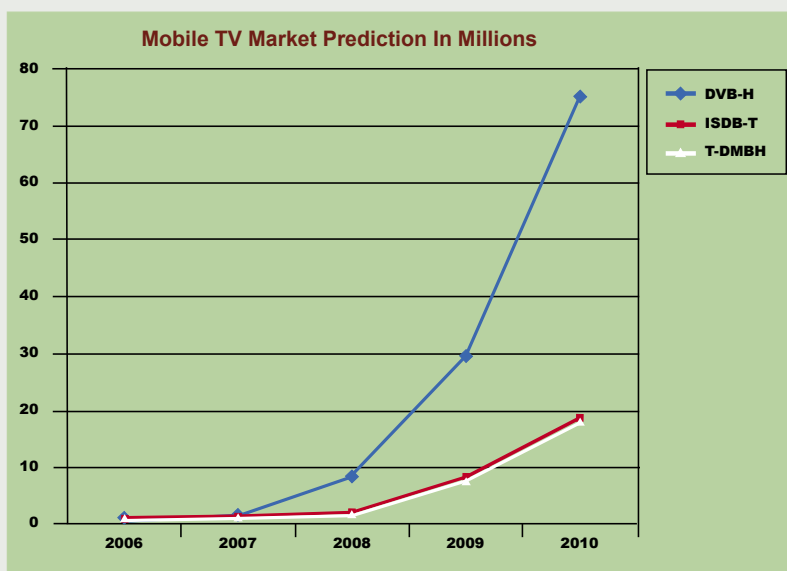

MULTIPLE ANGLES

Georges Martinez, Mobile Broadcast & Multimedia Manager
Motorola & Chairman DVB-CBMS (Convergence of Broadcast and Mobile Services)

In the past two years, significant players in the industry have started concentrating resources on mobile TV from multiple angles:

- Cellular operators have identified TV over 3G as an attractive service offering but have acknowledged the need for a true broadcast bearer associated to their network in order to sustain growth;
- Concurrently, broadcast network operators see in mobile TV the opportunity for growing their core business (i.e. deploy and densify broadcast networks) as most of the DTT deployments will finalise within the current decade;
- TV service providers contemplate mobile TV as a means to significantly expand their subscriber base by targeting individuals in addition to the current cable and/or satellite households;
- Content providers have already seen the attraction of exclusive content to 3G subscribers and are willing to increase their numbers.

At the end of the day, there is a true demand that has been confirmed by multiple market studies and trials run all over the world. However, to reach the industrial phase, the business framework has to be set up through appropriate regulation. Spectrum has to be made available, taking into account two challenges: Deployment of DVB-H short term requires allocating spectrum in the busy UHF band already used for analogue TV and DTT, such spectrum should be available for mobile indoor coverage at least in most major urban areas; Deployment of DVB-H in the longer term needs identifying what part of the spectrum dividend remaining after the analogue TV switch off is allocated to DVB-H for nationwide

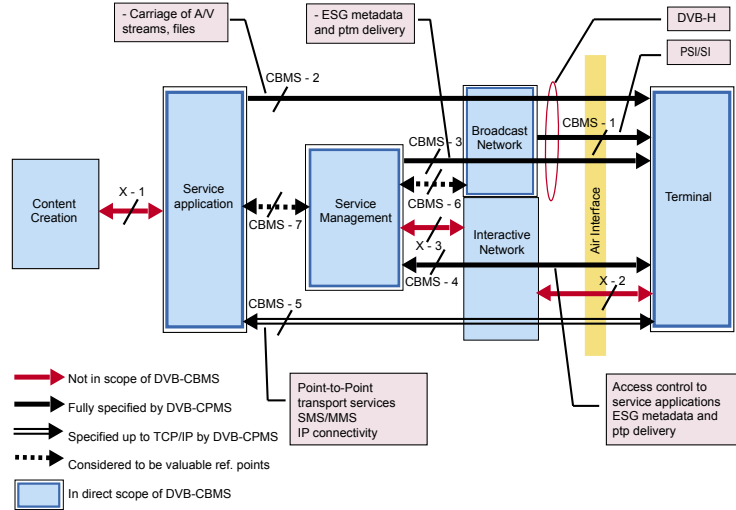

Figure 1: IP Datacast over DVB-H system architecture

coverage. Considering that mobile TV over DVB-H will make use of scarce spectrum resources, regulators will have to indicate whether DVB-H capacity will be allocated to service aggregators or service editors (i.e. per TV channel) and how incumbents will have access to resources for mobile TV, especially if they are already operating in other segments like cellular, cable, satellite and xDSL. Last but not least, industry players have to agree on technical specifications in order to avoid market fragmentation between different solutions. On the latter, DVB has taken a major step by approving in October 2005, after 18 months of intense work, version 1 of a set of specifications that describes how to make IP Datacast over DVB-H, in other words the essential components to deploy mobile TV. The process was initiated at the end of 2003 when a set of technical requirements were prepared and used as input to a call for technologies,

leading to a response from over 30 companies. DVB will deliver a set of specification documents that covers use cases, architecture, PSI/SI signalling, content delivery protocols, electronic service guide, service purchase and protection. The architecture document identifies several reference points and interfaces (Figure 1) but version 1 of the specifications only focuses on:

- What will be delivered over DVB-H (audio, video, subtitles, files),
- How it will be delivered (real-time streaming, file push),
- How it is described (electronic service guide),
- How it is protected.

In version 1 of the specifications, most of the key principles for IP Datacast over DVB-H are fully defined and related protocols fully specified (Figure 2). Among those principles, as much as possible of the service and signalling elements are carried on top of the IP layer in order to enable the reuse of the IP Datacast framework on other bearers.

The expectations around these specifications were such that a number of companies demonstrated pre version 1 implementations during IFA and IBC in September 2005.

The next steps in the technical work within DVB will include as a starting point the preparation of implementation guidelines for each of the specification documents available, with the objective to guide implementation in the early days of mobile TV using IP Datacast over DVB-H.

ESG metadata	Files	HE-AACv2	H264	Subtitles		
ESG container		ISMACryp				
FLUTE		RTP / SRTP			KSM	KMM
ALC		UDP				
		IP / IPSEC				
PSI/SI		DVB-H				2G/3G

Figure 2: IP Datacast over DVB-H protocol stack architecture (indicative)

Eurovision moves to HDTV using DVB-S2 technology

WORLD CUP READY

Didier Debellemanière,
Eurovision Technical Development, EBU

Eurovision is the operational branch of the EBU (European Broadcasting Union). It operates one of the largest contribution networks in the world and provides services to European broadcasters. A satellite network using about 50 main earth stations in Europe and permanent satellite capacity on several satellites (W3A, NSS7, Asiasat) is complemented by a fibre network connecting 15 major cities in Europe and the USA.

The Eurovision network was created about 50 years ago and was using microwave links to connect the TV centres of the national broadcasters. During the 1980's, satellite started to replace the terrestrial radio links, and allowed easy long distance communications.

In 1998, the satellite network was digitalised to take advantage of the better performance of digital transmissions. At this time, Eurovision was the first operator to use the DVB-S

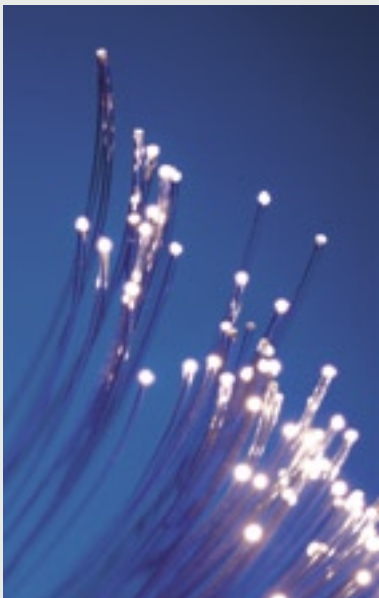

technology for satellite TV contributions. Compared to the well established 34 Mbit/s ETSI standard, the DVB-S offered efficient MPEG-2 based compression and greater flexibility. Unlike DTH networks, this contribution network has from the beginning used a 4:2:2 encoding structure.

Three years later, Eurovision launched the Xtranet network. Xtranet is a data distribution network using IP/DVB transmissions. Over 150 servers have been deployed all over Europe. Each one is connected to a small satellite dish and receives a permanent data carrier transmitted from Eutelsat W3A. The data is stored in the server hard disks, and can be accessed through a web interface from any PC connected with a local network to the server. The Xtranet network allows the distribution of metadata associated to the News Exchange between the Eurovision members.

In spring 2005, several DVB-S2 solutions were presented by manufacturers and made available on the market. Tests were organised to check the performance of the equipment in real operating conditions and the interoperability between different manufacturers.

One requirement during the tests was to keep the same operational margin (uplink and downlink) on the satellite. To reproduce the worst conditions, the test was done on a fully loaded transponder. The DVB-S transmission was established as reference, and two series of measurements were made: a measure of the occupied bandwidth at

a constant bit rate (payload), and a measure of the payload at a constant bandwidth. The DVB-S configuration used as a reference was QPSK 7/8 Roll-off 0.35. For DVB-S2 we used 8PSK 2/3 Roll-off 0.20.

The results were very encouraging: For the same spectral occupation, DVB-S2 offered 20 percent throughput increase. Alternatively, for a fixed throughput, it offered a reduction of 25 percent in spectral occupation. The interoperability between the different equipment tested was perfect. Eurovision Operations will operate the Asian and European distribution for the 2006 FIFA World Cup in Germany. Three picture formats will be distributed to Europe – two SD (4:3 and 16:9) and one HDTV. Another 4:3 feed will be distributed to Asia.

Considering the very encouraging results of our tests, DVB-S2 equipment will be used to carry the HDTV feed. Half of a W3A transponder (36 MHz) will be used, allowing a bit rate of about 60 Mbit/s. This should allow a seamless transmission of the pictures. Later, they will be used to feed several new HDTV channels scheduled to be launched at the end of 2005 or the beginning of 2006. All of them will use MPEG-4 AVC compression (and DVB-S2) around 12 Mbit/s.

All the satellite modulators in the Eurovision satellite network will be replaced with DVB-S2 models before the end of this year. The HDTV receivers will be introduced step by step to follow the demand for HDTV transmissions.



NEXT GEN ARRIVES...

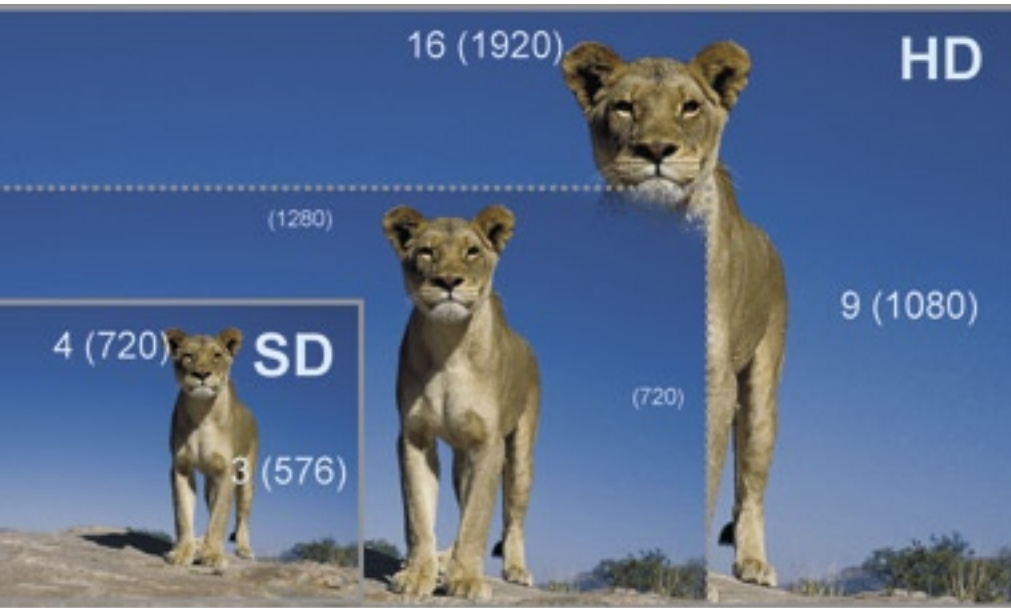

Europe has seen the launch of the next generation of HDTV services using the DVB-S2 satellite standard and H.264 compression. In October the ProSiebenSat.1 Group in Germany became the first TV broadcaster in Europe to use the new high resolution broadband format, with two channels broadcasting in HDTV alongside the

standard format. Both HD stations are available via the ASTRA satellite system.

"The new digital TV technology is a step into the future of television. With Sat.1 HD and ProSieben HD we're helping the new high resolution standard get established," said Guillaume de Posch, CEO of the ProSiebenSat.1 Group. "I'm

delighted that the impetus for the entire European market has originated from Germany. It shows that the German TV market is not just one of the most competitive, but also one of the most innovative in the world".

The ProSiebenSat.1 Group plans to strengthen this initiative for the further evolution of TV with cooperative ventures with other companies.

ProSieben has an arrangement with Sony, and Sat.1 has one with Sharp Electronics Germany/Austria. Both ventures are planning extensive, long term multimedia marketing campaigns on HDTV to alert consumers to the immense improvement in quality that the high resolution format offers.

Besides crystal clear, enticingly sharp images in 16:9 format, viewers with the right equipment can also enjoy Dolby Digital sound. Audio encoding uses the AC3 standard. Conexant enabled the first H.264 decoding for Sat.1 HD and ProSieben HD.

Other European broadcasters including Britain's BSKyB, France's CanalSat, Germany's Premiere and Italy's Sky Italia have all promised HDTV by June 2006 in time for the FIFA World Cup, which will be used as a showcase for the format.

DVB-SCENE : 08

...WITH A CHOICE OF BOXES



Pace Micro Technology's DS810 set-top box incorporating DVB-S2 technology and H.264 compression is being used by industry operators and partners to develop HD services and applications. A DS810 variant has already been sold to Premiere in Germany.

The DS810 is a multifunction HD decoder, for viewing both MPEG-2 and MPEG-4 AVC/H.264 HD content as well as existing standard definition (SD) programming. It comes with integrated conditional access and integrated common interface for most DVB descrambling systems. Other features include digital content protection (HDCP) for securely passing digital signals to the display, favourite channel listing, multilingual on-screen menus, a quick and extensive EPG with a preview for up to eight days, DVB subtitles and parental control.

The DS810 can be configured for use with most display screens and connector types, including HDMI. In addition, the DS810 can output HD content to a HDMI display and simultaneously output reformatted SD content to a second TV via the SCART connector.

David Gillies, Director of Technology at Pace commented: "We are creating a new ecosystem in the digital TV world. Combining H.264 advanced compression with DVB-S2 channel coding can deliver up to six HD channels in a single 36 MHz transponder, roughly equivalent to the same number of SD channels possible when MPEG-2 DVB-S products were first launched 10 years ago!

"We recommend that all satellite operators launching new SD and HD services use the extra data capacity supported by DVB-S2."

BBC TO TRIAL HDTV



The BBC has announced that it will trial broadcasts of HDTV in 2006. In the limited technical trials, it is planned to simulcast highlights of BBC One's peak time schedule in HD on satellite and cable, as available, from mid 2006. The broadcaster is also seeking to run a technical terrestrial trial in the London area at the same time. This would not affect reception of existing Freeview channels (digital free-to-air services). The BBC is considering collaboration with other broadcasters on the terrestrial trial. The purpose of the trials is to test delivery and reception of HD broadcasts on the major television platforms.

The trial will start on each platform once they become technically viable, and it is expected that these trials will last for about a year. There will be no impact on any current standard service. Some BBC programmes, such as 'Rome' and 'Bleak House', are already made in HD and the BBC has a target to move all production to high definition by 2010. The HD trial will enable the BBC to test the end-to-end HD production and distribution chain, from capture and post, to playout and coding, to transmission, reception and viewer experience. For the terrestrial trial, the BBC will

apply to the regulator Ofcom for temporary use of an unused frequency currently not allocated to broadcasters and unsuitable for conventional broadcast use. Capacity for high definition broadcasts on Freeview will be very limited until digital switchover - between 2008 and 2012. Switchover will free some extra spectrum as analogue services are switched off. Ofcom is to decide how this freed spectrum is to be used. The BBC would like to see some frequencies made available to broadcasters for high definition broadcasting and is working with other broadcasters, Ofcom and the government to explore this possibility.

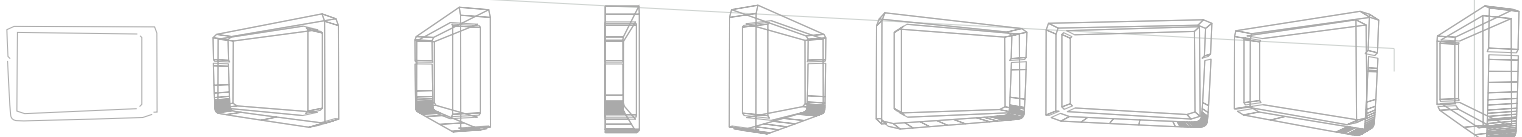

The breakthroughs in compression technology with H.264 combined with the superior efficiency of the DVB-S2 standard are key in enabling broadcasters and network operators to provide HDTV services. One of the first operators to offer HD services is Germany's Premiere who will broadcast three HDTV channels covering sport, movies and documentaries before the end of 2005. Philips is providing its DSR 9005 HD set-top boxes to Premiere for broad distribution via retailers in Germany and Austria with whom Philips cooperates.

The DSR 9005 set-top box can decode H.264 based HD signals and incorporates HDMI digital connectivity. It can receive both HD and SD, pay-TV and free-to-air programmes, and has a common interface for additional pay-TV services other than those of Premiere. Other features include Philips' intuitive Euphoria interface for easy navigation, a seven day Electronic Programme Guide and a five-in-one multi-brand remote control.

An important driver for the roll-out of HDTV services is consumer demand for HD capable flat panel TV sets, partly driven by 'HD ready' labelled TV sets that have now reached affordable price levels. By the end of 2005 more than 90 percent of Philips' European range of large screen flat TV sets will carry the EICTA recommended 'HD ready' label. In addition to the roll-out in Germany, Philips will supply its 'HD MediaSat+' set-top box in the first half of 2006 to support the HD Canal+ Le Bouquet launch in France, its IPTV solution to BT in the UK and its cable HD solution to UPC in the Netherlands.



PROTECT & MANAGE

The publication in November of DVB Blue Book A094, Content Protection & Copy Management (DVB-CPCM), signals a major milestone in the work of the DVB on a specification for persistent protection for commercial content in consumer digital products and home networks.

The DVB Content Protection Technical (CPT) sub group of the Technical Module, led by Chris Hibbert of Walt Disney TV International, has produced the first three elements of the specification working to the Commercial Requirements produced by the Content Protection sub group of the Commercial Module, led by Giles Godart-Brown of BSKyB. This follows in the tradition of the DVB of only producing specifications which are identified as commercially required by the market and supported by consensus among the membership.

CPCM manages content usage from acquisition into the CPCM system until final consumption, or export from the CPCM system, in accordance with the particular usage rules of that content. Possible sources for commercial digital content include broadcast (e.g., cable, satellite, and terrestrial), Internet based services, packaged media, and mobile services, among others. CPCM is intended for use in protecting all types of content – audio, video and associated applications and data. CPCM provides specifications to

facilitate interoperability of such content after acquisition into CPCM by networked consumer devices for both home networking and remote access. The work on DVB-CPCM, which started five years ago, has been supported by a broad representation of DVB members from all the constituencies of interest; content providers, broadcasters, distribution platform operators, consumer product manufacturers, and technology providers. As can be imagined content protection in consumer products and some free-to-air broadcast markets is a potentially contentious issue. It has therefore taken this time to embrace the concerns of all the players in the market and for all the parties to reach a level of understanding of each other's present and future business models. CPCM is therefore designed to accommodate a variety of business models and not all implementations will require the full functionality.

The release of the first three elements of the CPCM specification; DVB-CPCM Reference Model, DVB-CPCM Usage State Information and DVB-CPCM Abbreviations, Definitions and Terms

are in the form of a Blue Book for informational purposes and liaison with other interested standards forums. When completed the DVB-CPCM specification will be submitted to ETSI for standardisation.

The contents of these first three core elements of the CPCM system are stable but may be subject to updates and changes in the light of ongoing work in defining the remaining two elements DVB-CPCM Authorised Domain Management and DVB-CPCM Security Tools & Application which will be released at a future date. An additional document, DVB-CPCM Implementation Guidelines, will give examples of different applications of CPCM in a range of markets and business models.

This first phase of the specification will address CPCM for digital content encoded and transported by linear transport systems. A later second phase will address CPCM for content encoded and transported by systems in accordance with future DVB specifications based upon Internet Protocols.

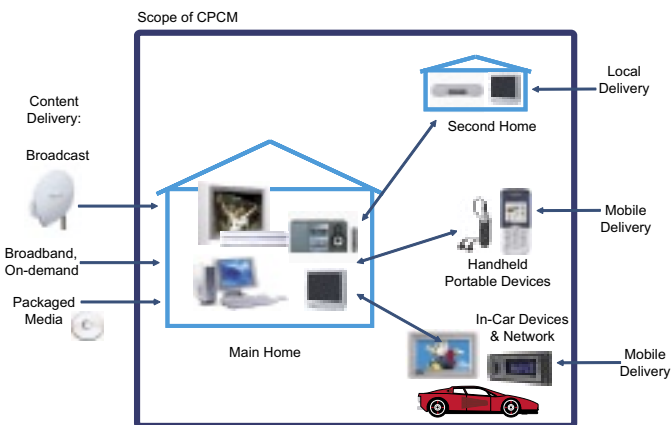

DVB-SCENE : 10

ON THE RADIO

TechniSat's new DVB-T radio is a mobile radio set that is able to receive radio programmes transmitted via DVB-T. The particular programme is indicated via a small display on the front of the device. By means of appropriate wiring, the radio can even be connected to a TV and be used as a DVB-T TV receiver.

The radio is being used in a one year pilot project organised by the Medienanstalt Berlin Brandenburg to test the public acceptance of radio via DVB-T. Since the beginning of September, 32 radio channels in Berlin have been on-air using DVB-T. TechniSat is participating in the project with 13 of its own radio programmes.



The DVB-MHP security framework: securing the entertainment experience

KEY TO INTEGRITY

Kevin Blackman, CTO, WISeKey SA



Kevin Blackman joined WISeKey in 2000 and has more than 12 years experience in project management, IT security, PKI, and telecommunications. Kevin holds a degree in electrical and computer engineering from the University of the West Indies and is a Certified Information System Security Professional, Information Systems Security Management Professional, and Information System Architecture Professional.

MHP extends the existing and successful open DVB standards for broadcast and interactive services in all transmission networks including satellite, cable, terrestrial and microwave systems. It supports many kinds of applications allowing broadcasters, network operators, and content creators to provide a rich interactive multimedia and Internet experience to their clients, thus opening a new vista of additional services and entertainment. However these new vistas also introduce the possibility of new threats and thus the MHP standard includes a strong security framework to secure MHP applications and consumers.

The MHP security model is designed to maintain integrity of content in the content delivery chain and to guard against potential problems such as:

- Malicious damage of the MHP device by an application
- 'Denial of Service' through competing applications, malicious attacks or other means
- Unauthorised use of user data
- Unauthorised use or theft of content
- Unauthorised use of the return channel

- Unauthorised access to the communication on the return channel.

The MHP thus provides authentication and verification systems that validate incoming applications. It provides capabilities to check the operation of an application and its use of the MHP's resources, as well as secure authentication mechanisms that allow access to secure applications or online sites. Furthermore, in the future a copyright system that manages the storage of content within the MHP is being considered, and an encryption system that guards against the theft of content is of course needed.

The MHP security mechanism is based on a Public Key Infrastructure (PKI) in order to support current and future needs; defining security requirements for consumer, service provider, device manufacturer, and broadcaster by providing confidentiality, integrity, availability, privacy and non-reputability. The PKI is owned by DVB Services Sarl, and after a tender and evaluation process WISeKey was selected to be its operator. WISeKey has thus

implemented the infrastructure, and also hosts and operates it. A Public Key Infrastructure is composed of Certification Authorities (CA), each possessing a key pair, one private and the other public, with the public key incorporated into a digital certificate. The Root Certification Authority is at the base of the trust chain and must be operated with extreme security, trust, and care. WISeKey therefore equips its facilities with multiple security controls such as biometric access, multi-tiered physical entry, micro cement and steel reinforced structures, sophisticated alarm systems, and onsite and remote surveillance to ensure Root CA safety. Staff are also highly trained and complete a strict trusted employee verification process. All core operations are supported by documented operational procedures; and backed by legal and service agreements that ensure the smooth, secure and efficient functioning of the system. The DVB Service PKI contains a minimum of three Root CAs, and these Root Certificates are embedded within

every MHP receiver, host, or client. These devices are thus able to verify the chain of trust to ensure the integrity of MHP content and ultimately safeguard consumers from threats. WISeKey provides the certification services that ensure the security, and availability of the core PKI infrastructure that is essential to the MHP community including:

- Security and operation of Root and Signing Certification Authorities
 - Root certificates for device manufacturers
 - Application signing certificates for content creators
 - Support and consulting to customers.
- The DVB Project and its partners have invested significantly to provide a safe and secure environment in MHP. It's in the interest of the entire community, including broadcasters, network operators, application developers, and device manufacturers to support the MHP security framework and ensure a fun and safe playground for us all.

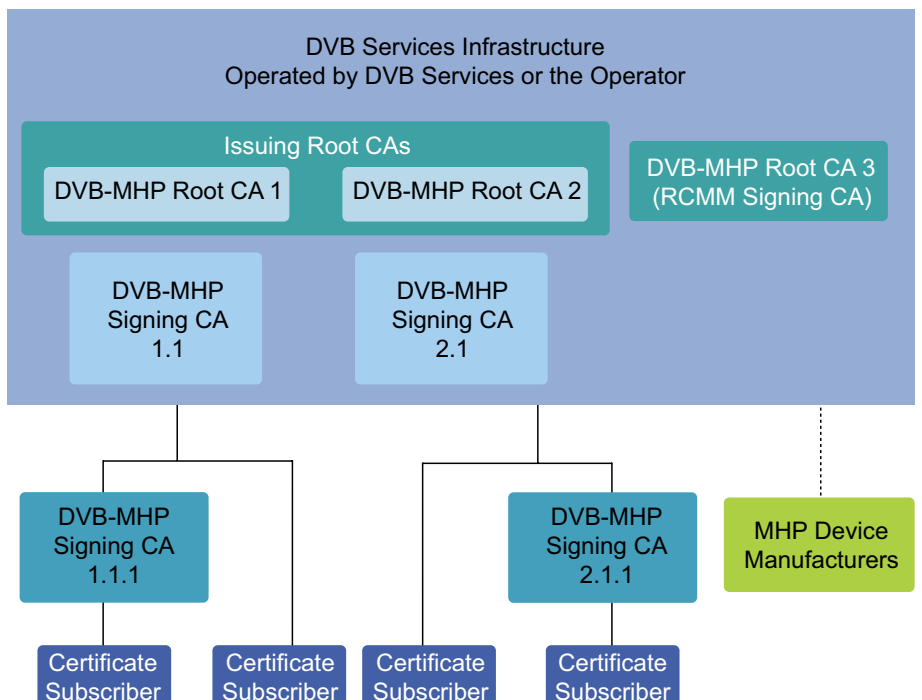

LOGO LOGIC

Peter MacAvock, Executive Director, DVB Project Office

When, around 12 years ago, the DVB logo was first sketched by Philippe Juttens of the EBU, little did we know that it would soon appear on tens of millions of pieces of equipment around the world. It can justifiably be described as one of the most recognised logos in the broadcast industry. The most important function of the DVB logo remains its indication of compliance to DVB standards. The DVB logo can only appear on a product if that product has been declared compliant through the online system available on the DVB website: www.dvb.org. This is open to all companies, including non-members of DVB, and is currently free of charge. Members may also use the logo in other circumstances, such as at trade fairs or on company publications, to highlight their membership. The use of the DVB logo is overseen by the DVB Project Office with ongoing support from a firm specialising in trademark law. In the past few years the DVB Project Office has also developed a series of sub-brand logos consisting of the DVB logo followed by a boxed letter or letters. These were developed as a means of differentiating between the different technologies developed by DVB, particularly in internal DVB publications and presentations. However, in recent times we have received an increasing number of requests to use these sub-brand logos, and indeed we have seen them used, with and without permission, in a variety of situations. Thus it has become necessary to outline a set of rules for their use that both protects our ability to police the use of the original DVB logo, a registered trademark worldwide, but also allows our members to contribute to the promotion of DVB technologies where appropriate. With this in mind, and acknowledging that guidelines we have issued in the past may have been overly restrictive, we now outline an amended set of guidelines. The DVB sub-brand logos may only be used by non-members of the DVB Project on receipt of written permission from the DVB Project Office. Such requests will be considered on a case by case basis. The DVB Project Office retains the right to withdraw permission to use the DVB logo at any time. The use of the MHP logo, another registered trademark, is also subject to a strict set of rules that are closely tied to the MHP licensing and conformance regime. These rules are clearly outlined on the MHP website: www.mhp.org.

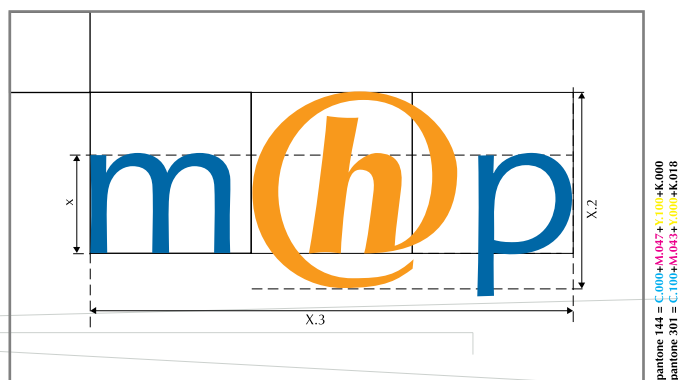

Sub-brand Logo Guidelines

- The DVB sub-brand logos may never appear on any product, its packaging, or its datasheet. The only logo that can be used in association with a product is the DVB logo, and then only when the product has been registered on the DVB website.
- The DVB sub-brand logos may be used only by DVB members in the context of the explanation or promotion of a particular DVB technology in presentations, publications or on graphics panels at tradeshows. Care must be taken not to associate the sub-brand logo with any specific product or products.
- All use of the DVB logo or sub-brand logos must be accompanied by a trademark acknowledgement, i.e. DVB is a registered trademark of the DVB Project or a circled "R" (DVB®-H)



THE CHALLENGE OF CHOICE



From new mobile TV markets to the challenge of integrating interactive content into existing programming; from impressive advances in video and audio coding to the complex jungle that faces those implementing digital rights management; from the myriad of potential broadcast business models to meeting the needs of consumers in an on-demand world - one could be forgiven for finding it all just a bit bewildering. This is why DVB World 2006 has been named 'The Challenge of Choice'. In aiming to meet and exceed the standards set in previous years, organisers the IAB, in conjunction with the DVB promotions and communications module, will once again present a wide ranging programme in Dublin next March. In a departure from previous years, the

first session, on the afternoon of March 1st, will present a picture of the truly global scope of DVB technology, with reports from a number of regions across the world. This session will be preceded by a yet to be announced keynote presentation and an opening address from the Chair of the DVB Project, Theo Peek. The second day will open with another keynote presentation followed by a comprehensive session on the subject of mobile TV covering DVB-H trial results, the issue of terrestrial spectrum for DVB-H services, and a panel discussion on the opportunities and challenges for broadcasters and telcos. The critical issue of MHP licensing will be addressed that afternoon, along with an overview of the impressive progress with iTV implementation in Italy.

Journalist Barry Flynn will chair a panel discussion that will explore the challenges faced by broadcasters and network operators in an 'on demand' world, and the day will close with a look at the thorny issue of digital rights management.

The increasingly important topic of HDTV will be the focus for Day 3 of DVB World 2006. David Wood will chair a session that addresses all aspects of the debate surrounding the launch of HDTV services in Europe and beyond: formats, codecs, displays, set-top boxes and content. The conference will close with a (hopefully!) lively debate about how best the limited terrestrial spectrum should be used. The DVB World 2006 programme is now available at www.iab.ch, along with details on registration and accommodation. See you in Dublin!

 **TeamCast**
Your team for Broadcast

DVB-T & DVB-H
ModulCast®

Easy-to-integrate, compact and truly cost effective modules for Transmitter, Base-Station, ENG and System integrators:

- ✓ High performance DVB-T / DVB-H modulators,
- ✓ Hierarchical MIP inserter for SFNs,
- ✓ Mobile DVB-T/-H antenna diversity receivers,
- ✓ Experimental DVB-H receiver,
- ✓ Ultra Low Phase Noise Synthesizers,

All the essential technical bricks needed to build up DVB-T & DVB-H high performance transmission systems at competitive pricing.

(for further information: www.teamcast.com)



BOOK NOW TO ENSURE YOUR PLACE



The Challenge of Choice

**Jurys Ballsbridge Hotel and Towers,
Dublin, Ireland**

1-3 March 2006

Technical, legal and commercial aspects of DVB presented by the experts. Digital Video Broadcasting has progressed at a pace unequalled by any other broadcasting technology since the introduction of radio broadcasting in the 1920s. Terrestrial Broadcasters, Satellite and Cable Operators are faced with the dilemma of how best to integrate the new emerging possibilities into their existing services. Choice is the order of the day. DVB World 2006 promises to be just as exciting as previous conferences with the emphasis on the choice offered dealing with the DVB worldwide situation, mobile television, MHP, DRM, HDTV and the future use of the terrestrial spectrum. If you care about digital media, you cannot afford to miss this event.

**DVB World 2006 programme, registration and hotel booking now available - www.iab.ch
Conference Coordinator: Ms. Claire Reynolds, E-mail: seminar@iab.ch,
Telephone: +353 (0) 87 2097770, Fax: +353 (0) 1 2899412**