

Tune in to Digital Convergence

DVB - SCENE

SOUND advice

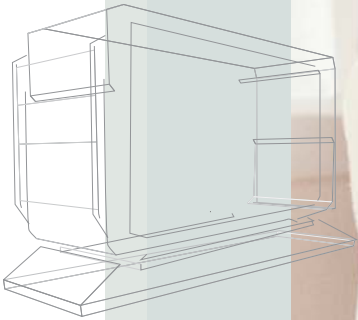

12

DVB®

The Standard for the Digital World

This issue's highlights

- > DVB 3.0
- > H.264/AVC
- > DVB-S2 at IBC
- > Audio for HDTV
- > Update: DTT in Europe



DIGITAL TV

WE'VE GOT IT ALL!

Cable ■ Satellite ■ Terrestrial ■ Free to Air
DVB-CI ■ IP TV ■ DVR ■ DOCSIS / EuroDOCSIS
PayTV / Fleet STB's ■ Conditional Access
Proprietary middleware ■ MHP/OCAP

ADB2000
series



Low cost
MHP-compliant
STB

ADB3200
series



Cable STB
with DOCSIS
cable modem

ADB7100
series



MHP DVR
Platform

ADB7100TWIN
series



One STB – two
TV sets solution

ADB7200
series



Advanced cable
DVR with
DOCSIS cable
modem

ADBx100W
series



Highly
configurable
Internet
Protocol (IP) STB

A word from the DVB Project Office

Year's End



Peter MacAvock, Executive Director

NEW MEMBERS

Digitenne BV
Electronic Frontier Foundation
Neotion
Sanio Mobile Silicon Ltd.
Zoran Corp

Published by the DVB Project Office,
c/o European Broadcasting Union,
17a Ancienne Route,
CH-1218 Grand Saconnex, Switzerland.
www.dvb.org & www.mhp.org

Editors: William Daly, Harold Bergin
Editorial and Advertising enquiries to: WHD PR
Email: news@whdpr.com
Telephone: +44 (0)20 7799 3100

All rights reserved. No part of this publication may be reproduced without prior consent of the publisher. All content correct at time of printing. © DVB-SCENE 2004. DVB and MHP are registered trademarks of the DVB Project. Certain other product names, brand names and company names may be trademarks or designations of their respective owners.

Printed by Lithmark Limited.
Design by GyroGroup.

The views expressed in this newsletter are those of the individual DVB members or guests and are not necessarily the views of the DVB Project Office or Steering Board.

Welcome to this final issue of DVB-SCENE for 2004 - the end of the year sees the DVB General Assembly and the Project planning its forthcoming year, putting its finishing touches on the next phase of the Project - DVB 3.0. As always, DVB needs to ensure that it retains its relevance in the world of digital television - this becomes more and more challenging as the body of DVB standards and their users increases.

We have also seen significant feedback from the DVB demonstrations at IBC '04. These saw the first live transmissions of DVB-S2, the first live decoding of H.264 at 720P50, the first live decoding of SMPTE VC-1 coming from an MPEG transport stream and finally, the first demonstrations of technologies likely to be included in the HDTV launches planned for 2006 in Europe. Since IBC, we have heard reports of the first H.264 chips starting to become available. Naturally, an essential element of HDTV launches will be the

timely availability of affordable set-top boxes incorporating both DVB-S2 and H.264. With this in mind, the DVB Project has just finalised its latest edition of the MPEG implementation guidelines incorporating H.264 and High Efficiency AAC.

2004 will be seen as the year of the Italian DTT launch and the significant deployment of MHP set-top boxes there. Seen as an improbable recipe for success at the outset, the first year has seen quite a successful market - and one in which there will be a limited legacy of non-interactive set-top boxes unlike, say, Germany. Time will tell how the specifics of the Italian model could be applied elsewhere. France is finalising its launch and we could see movement in Spain shortly, too.

Finally, it remains for me to wish all DVB participants and DVB-SCENE readers the compliments of the season and good luck for 2005 from all of us on the DVB-SCENE editorial team.

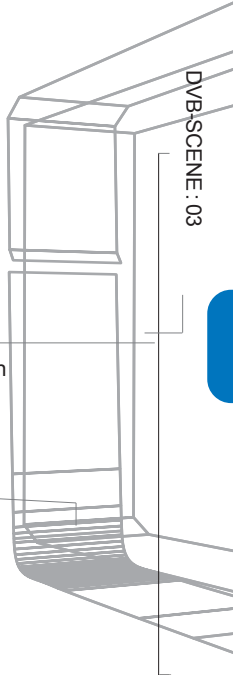

Season's Greetings
from the Project Office.

Wishing you the very
best for 2005.



Eoghan O'Sullivan, Désirée Noetzli, Santa Claus, Eva Melamed, Peter MacAvock



The Next Phase DVB 3.0

Graham Mills, Chairman,
DVB Commercial Module

DVB-SCENE : 04

It is now eleven years since DVB was founded and its impact on the world of broadcasting and related markets and technologies has probably met or exceeded the expectations of its early members. Earlier this year DVB's Chairman, Theo Peek, asked whether DVB had reached and end of its life as a specifications setting body or whether there was a new phase of work that needed to be done and would be supported by its members. On 28th October the General Assembly decided more needed to be done and unanimously approved a strategy for a new phase of work for DVB to be delivered over the next two

to use; peer to peer technology will enable personal content to be created and distributed in new ways that may need to use DVB technology; for media content storage, content management tools and techniques will be needed that label items as we store them and help us search for multimedia data; and portable video players are now emerging where content is delivered or updated via fixed or mobile IP networks. More and more examples will emerge of these kinds of requirements

The vision for DVB, over the next phase of its development, is to be an enabling forum for pre-competitive standards setting in the 'connected world' of

Management, including compliance issues

- c. Audio-visual coding guidelines
 - d. MHP support and possible extensions of GEM into new businesses
 - e. IPR issues
 - f. Security.
6. IP for contribution of DVB services. This is a challenging and exciting new remit for DVB and we look forward to continuing the DVB traditions, winning broad industry support for innovative new specifications that meet a specific market need.

“...the impact of the Internet, mobile communications and digital broadcasting are having a powerful and direct impact on our lives...”

or three years. We have decided to build on the strengths and past success of DVB to deliver a further set of market led specifications and guidelines to support the new opportunities and requirements that are now emerging in the early part of the 21st century.

The world around us is becoming a 'connected planet'. Networking and access to content are becoming ubiquitous. In most developed nations, the impact of the Internet, mobile communications and digital broadcasting are having a powerful and direct impact on our lives – both at work and at home. Some of the thinking that will underpin our future work includes: current ways of binding content rights to devices (smart cards, storage devices) will need to be replaced by mechanisms that bind those rights to the individual, regardless of which device they want

networked digital media and applications.

The new phase of work, known as DVB 3.0, will incorporate the following work items:

1. Convergence of broadcast and mobile services (including systems like WiFi, WiMax, 2G, 3G).
2. Convergence of broadcast and fixed IP network services (including topics like DSL, QoS management, local storage).
3. Solutions to support service interoperability across multiple networks and platforms (including work on content coding, middleware, portable content format, in-home distribution).
4. Completeness study on HDTV and possible amendments to our HDTV toolbox.
5. Continuation of existing important work items:
 - a. Broadcast technology
 - b. Content Protection and Copy



Graham Mills is a senior manager in BT Retail. He and his team have led the development and launch of a number of new products, services, acquisitions and joint ventures. Chairman of the DVB Commercial Module, he has made a substantial contribution to the DVB industry group since its formation in 1993, setting the international specifications for digital TV and interactive services.

Graham graduated from King's College Cambridge with an honours degree in engineering. He holds an MBA from Cranfield School of Management.

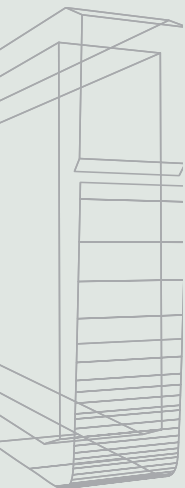

NEW TOOLBOX

Ken McCann, ZetaCast
Chairman of TM AHG on Audio Visual Content (TM-AVC)

One of the earliest DVB specifications, the Implementation Guidelines for Video and Audio Coding in Broadcasting Applications based on the MPEG-2 Transport Stream, has recently been revised to add new options. Originally published in 1995 as DVB Blue Book 001, the latest revision of TS 101 154 adds the option of H.264/AVC video as an alternative to the original MPEG-2 video. The range of codecs for audio has also been extended to give a total of four options: MPEG-1 Layer II, AC-3, DTS and HE AAC.

This revision marks a move towards a 'toolbox' approach to audio and video coding. It recognises that we are now in a multi-codec world and that DVB applications require the flexibility to choose the most appropriate tool for the job. The disadvantage of this toolbox approach is that interoperability becomes a more complex issue. If IPR costs could be ignored then there would be an argument for requiring all decoders to support the original MPEG-2 video and MPEG-1 Layer II audio as a guaranteed-baseline interoperability point. However, the commercial reality is that the cumulative cost of all of the licence fees (e.g. \$2.50 for the MPEG-2 video decoder) would not be economically viable.

To prevent the DVB toolbox from becoming too cluttered, any new audio or video codec must offer some commercial or technical benefit. Four criteria have been adopted that codecs must meet before they are considered: Significant market demand attested by at least five DVB members from at least two constituencies; Technical performance verified by independent testing; Documented in the public domain by a recognised standards body; and IPR available on fair, reasonable and non-discriminatory terms.

The new H.264/AVC video coding algorithm offers comparable quality at around half the bit-rate needed for MPEG-2 video. This improved coding efficiency is particularly important when considering bit-rate hungry

applications such as HDTV. The specification was published in May 2003 by ITU-T as Recommendation H.264 and by ISO/IEC as 14496-10. Three Profiles define subsets of the syntax and semantics: Baseline Profile, Extended Profile and Main Profile.

The Fidelity Range Extensions Amendment of H.264/AVC, agreed in July 2004, added some additional tools and defined four new Profiles (of which only the first is relevant for broadcasting applications): High Profile, High 10 Profile, High 4:2:2 Profile and High 4:4:4 Profile.

The relationship between High Profile and the original three Profiles, in terms of the major tools from the toolbox that may be used, is illustrated by Figure 1.

For SDTV and HDTV, the most relevant profiles are Main Profile and High Profile. Both of these allow the use of the most powerful variable length coding scheme: Context Adaptive Binary Arithmetic Coding (CABAC). It has been estimated that this gives about 10 to 15 percent saving in bit-rate compared to the simpler alternative of Context Adaptive Variable Length Coding (CAVLC). In addition, the High Profile allows the use of an 8x8 transform and encoder-specified quantisation weighting matrices. It has been estimated that this gives about 10 percent improvement in coding efficiency compared to Main Profile when using progressive HDTV source material.

As a result of these considerations, TS 101 154 requires High Profile



DVB-SCENE : 05

support for HDTV decoders which implement H.264/AVC. Only Main Profile support is required for H.264/AVC SDTV decoders, although High Profile can be used as an option.

So have we now finished with revising the Implementation Guidelines? Far from it! It is a living document that will continue to evolve as the needs of DVB members develop. A further revision with improved PVR support is in the pipeline and two additional codecs have already been identified as having significant market demand: Enhanced AC-3 audio and VC-1 video.

Ken McCann is a director & co-founder of ZetaCast, an independent technology consultancy company specialising in digital TV. Prior to founding ZetaCast, Ken worked for NTL, Symbionics and Philips.

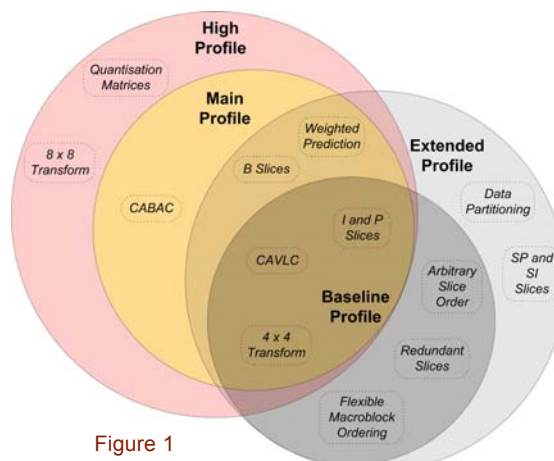

Figure 1



LANDMARK EVENT

Simon Gauntlett, BBC R & D Engineer

transport stream, using the advanced coding options available in the latest draft of the MPEG guidelines document. Both channels used a scanning format of 1280x720 pixels, progressively scanned, with the B SkyB content being encoded using the H.264/AVC system and the EBU

content with VC-1 (Windows Media 9 Advanced Profile). The programme content for the EBU part of the demonstration was produced in collaboration between BBC R&D, SVT and NDS, and BBC R&D also encoded the material, and provided the means for decoding and displaying it.

Over the past year or so, there has been increased interest within Europe in the possibility of broadcasting High Definition Television (HDTV) programmes. During this period, the DVB project has developed two major specifications which will make such a transition towards HDTV more achievable - the DVB-S2 satellite transport specification and the latest draft of the MPEG implementation guidelines.

A landmark demonstration was given of the performance available from these two specifications on the DVB stand at IBC in September. Two HDTV programme channels, one provided by the EBU and the other by B SkyB, were multiplexed into a single MPEG

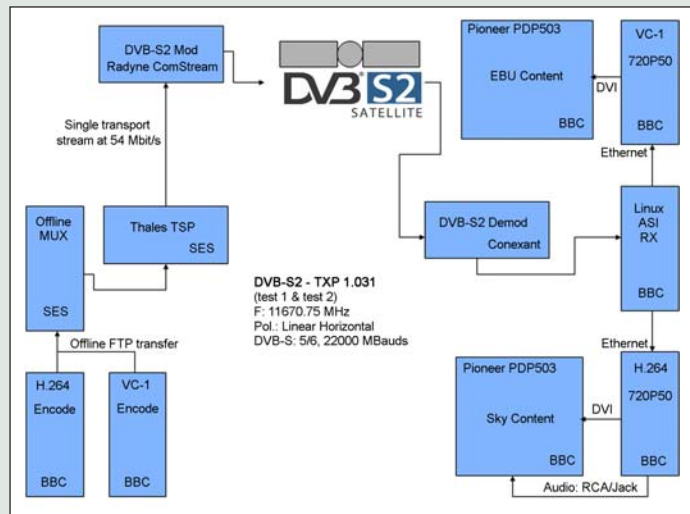

DVB-SCENE : 06

KEEPING UP WITH HD DEMANDS



In a demonstration at IBC for Advanced Video Coding, LG.Philips showed how it is keeping up with the demands of HDTV with its 55 inch LCD display. The picture quality is enabled by Super In-Plane Switching (IPS) technology that, among others, enables uniform contrast and minimum colour shift at the widest viewing angle.

In the absence of any real-time hardware encoders, non-real-time software encoding was used, based on software tools from Moonlight (H.264/AVC) and Microsoft (VC-1). Each channel was encoded at around 8Mb/s, stored on a server and played out in real-time into the satellite modulators. The DVB-S2 modulation was carried out by Radyne ComStream, and the bitstream uplinked to a 54Mb/s transponder made available by SES Astra at 19.2 degrees East. Real-time demodulation was carried out using equipment by Conexant. Decoding of the video bitstreams was carried out in software running on two 3.2 GHz Pentium 4 PCs running Directshow filters. An additional Linux PC was used to distribute the transport stream from the satellite demodulator to the two decoding PCs.

The timescale for integrating and debugging the demonstration was extremely ambitious, and it was not until the day before the exhibition opened that successful decoding of both channels was achieved. Some optimisation of the software was even being carried out during the first day of the exhibition itself! However, the outcome was an extremely



successful and popular demonstration, which provoked significant interest in the corridors of IBC and which, once completed, ran non-stop for the final two days of the exhibition without any operator intervention. It was the world's first live demonstration of a high definition broadcast using the latest generation of advanced video codecs and delivered via DVB-S2.

Simon Gauntlett holds a Masters degree in Electronic Engineering from Exeter University. He joined BBC Research and Development department at Kingswood Warren in 1999. Recently, working on the delivery of High Definition television, he demonstrated delivery of MPEG-2 HD over DVB-T at Mediacast 2004 before turning attention to advanced video codecs.

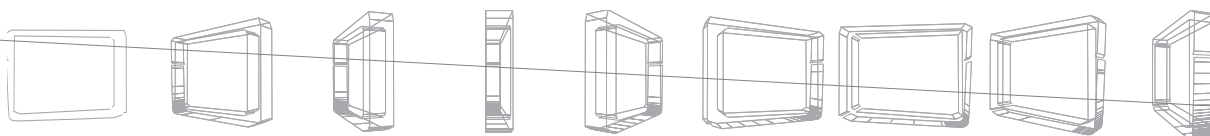

REAL-TIME DEMODULATION FOR S2

The Conexant CX24116 DVB-S2 demodulator was a critical component in demodulating the live over-the-satellite DVB-S2 signal in the DVB stand at IBC. The CX24116 is fully compliant to the DVB-S2 broadcast specification and supports backwards compatibility to the DSS and DVB-S modes. It has a highly efficient and robust automatic acquisition algorithm that searches and acquires the carrier within $\pm 10\text{MHz}$ range during initial acquisition and performs a smart search to reacquire during fade conditions. CX24116 has an on-chip micro-controller for fast signal acquisition, Es/No estimation and system monitoring. Furthermore, the on-chip micro-controller saves software integration time by minimising the external driver code.

The CX24116 DVB-S2 demodulator IC used in conjunction with Conexant's CX24118 RF Tuner IC provides a complete satellite front-end system solution that enables satellite STB providers to deliver cost effective, digital STBs that support a range of consumer video services, such as transmitting HDTV channels.

The key benefit of CX24116 is that it is based on an open DVB-S2 standard and offers an alternate path for service providers to use advanced modulation (8PSK) with BCH/LDPC FEC to realise a 35 percent increase in satellite throughput.

MPEG'S ADVANCED AUDIO CODING (AAC) FOR HDTV AND OTHER TV SERVICES



Harald Popp, Head of IIS Department for Multimedia Realtime Systems, Fraunhofer IIS Erlangen

The introduction of new HDTV services called for a video format that is more efficient than MPEG-2 Video. The new ITU/ISO standard H.264/AVC allows a decrease in bitrate demand by a factor of 2 to 3.

As the new video format is not backwards compatible, new receivers are required (e.g. for MPEG-2 Transport Stream based DVB services) which allow the introduction of new audio formats at the same time. Of course, a reduction of 64 kbps per audio channel (comparing MPEG AAC with MPEG-1 Layer II) is equivalent to only a few percent of the total bit budget within an HDTV service. For SDTV services, the saving of audio data becomes already more significant – even more so, if multilingual programmes come into consideration. Finally, in the case of networks with limited transport



The development of AAC began in 1994 by AT&T, Dolby, Fraunhofer and Sony and by 1997 the new format had entered the MPEG standard as MPEG-2 AAC. Later on with the development of the MPEG-4 Audio standard, AAC was further enhanced and amended, e.g. for delay-critical

and an increasing number of software vendors (like Real or Nero) are supporting HE AAC; HE AAC is also part of the ISMA (Internet Streaming Media Alliance) specification. Furthermore, HE AAC (amended by a further 'parametric stereo' tool) has become one of two recommended audio formats for music delivery to and between mobile devices (3GPP rel. 6.x), and first services (e.g. by O2) based on HE AAC have already started in 2004.

There is more to come. Time for DVB to catch up!

“... achieves ‘perceptually transparent’ sound quality ...”

capacity (e.g. IP-based DSL-TV, or within DVB-H applications), it is of vital importance to give the video signal as much of the available data as possible to achieve a reasonable image quality.

Today's most efficient audio format was standardised in 2003 as High Efficiency AAC Profile (HE AAC) within the MPEG-4 Audio Standard. HE AAC is a combination of the perceptual audio codec AAC LC (Advanced Audio Coding Low Complexity) and the bandwidth expansion tool SBR (Spectral Band Replication). AAC LC itself achieves 'perceptually transparent' sound quality at 64 kbps per channel; using the SBR tool, a pretty good sound quality can be maintained for bitrates as low as 32 kbps mono or 48 kbps stereo or 128 kbps 5.1 surround.

applications or for scalable use of multimedia content.

Due to this time line, and due to its outstanding performance, the AAC format is already in use in numerous important applications. In digital broadcasting, all of Japan's ISDB services are based on AAC as the only sound format; the US based XM satellite radio service is using HE AAC, as well as the international standard for terrestrial long/medium/shortwave radio, Digital Radio Mondiale. HE AAC has become the mandatory format for the 2nd Session DVD-Audio and is part of the DVD-AR (Recordable DVD-Audio) specification. AAC is the sound format for Apple's most successful music download service iTunes and is supported by all iPods. Numerous MP3 players also playback AAC files,

Harald Popp joined the Fraunhofer Institute for Integrated Circuits (IIS) in 1984. He developed the DSP hardware for various audio codecs (e.g. ASPEC, MP3). Since 1993, Harald played a major role in the development of Fraunhofer's licensing business, first for MP3 and later for AAC and other technologies in the field of audio and multimedia. Today, Harald is head of the IIS department for Multimedia Realtime Systems, focussing on efficient implementations of audio visual coding formats and related technologies.

MOZART OVER THE PHONE...

Ted Laverty, Director Business Development, DTS Europe

If HDTV is to fully realise its commercial potential for broadcasters to provide additional and improved revenue streams from premium and specialist programming, then it must surely meet the expectations of the wide and disparate range of the European viewing public for improved sound quality. HDTV, a standard designed to see us well into the future, should cater for the complete spectrum of consumer preferences.

The advent of HDTV broadcasting will engender heightened expectations on the part of consumers – and, importantly, paying consumers – concerning quality and the viewing experience. Expectations will be driven by all of the above and by the forces of marketing ranged by the CE manufacturers, broadcasters and programme makers selling content.

The arrival of modern multichannel cinema sound and its subsequent migration into the consumer electronics markets was the result of years of development to match widescreen pictures with realistic sound presentation. In both cases, development has reached to achieve best possible quality parameters. In the case of DVD, the success of optional high bit-rate audio with consumers has been a major business driver for DTS. The importance of high quality audio for video content is recognised by the mandated inclusion of DTS in both high definition optical disk formats, HD-DVD and Blu-ray.

With HDTV, digital broadcasters have the opportunity to compete in delivering premium sound and picture quality across a diversity of content. The ability to specify highest quality transmission standards for premium quality programming becomes all the more critical when success is no longer measured in mass market viewing figures but in incremental programming revenue streams.

Early adopters of HDTV will almost certainly be those who plug their set-top boxes into home theatre systems. These are precisely the people who exert the greatest demand for quality. They are also the audience who will look to HDTV for premium

programming – movies, concerts, opera, drama, premier sporting events – and be willing to pay for it. The benefits of especially bit-rate-efficient codecs are apparent in reducing the demands on bandwidth; DTS' scalable, single bit stream solution allows for multichannel audio over a range of broadcast rates. However, one size does not fit all. Developments in low bit-rate coding effectively enable a host of mobile, handheld, IP and interactive audio applications and, in their more advanced variants, will provide acceptable audio quality for a

consumer business by offering the premium quality audio option for DVD-Video. Broadcasters now have this same technology available to them to provide something which can realistically be described as ultimate audio quality. Beyond which, as a scalable, single bit stream solution, already capable of lossless compression, it also future proofs such a claim.

"Mozart sounds good over the telephone" is not a good enough argument.



good deal of content. They are not going to satisfy quality expectations for premium content, however. For that we must look to the highest standards set by entertainment software and the commercial success of the content that embraces them.

Broadcast sound production standards are traditionally very high and on a par with the film and music production industries. Witness the BBC production resources massed for the annual Proms concerts, or the meticulous microphone engineering and resultant sporting sound effects courtesy of Athens Olympic Broadcasting's production for the Olympic Games. These offer further opportunity to be exploited in providing premium entertainment experiences. Will discerning viewers really appreciate an HDTV broadcast of the Vienna Philharmonic New Year's Concert at low audio bit-rates, when their expectations are informed by DTS 96/24 music video or Super Audio CD music releases?

In Issue 11 of DVB-SCENE, Adam Watson Brown, Head of Sector for Media in the European Commission's Information Society department, describes HD as 'the ultimate in video and audio quality'. DTS has built its

Ted Laverty is Director of Business Development, DTS Europe, responsible for Broadcast and Interactive Technologies. Based in the company's Research & Development office, Northern Ireland, he joined DTS in August 2001. Ted has an extensive career history in the audio industry spanning over 15 years. Prior to joining DTS he worked for high quality audio codec developer, Audio Processing Technology Ltd, acting as their LA based US General Manager. Ted is a Chartered Engineer and member of the IEE and AES.



HDTV – IS THE TIME RIGHT FOR EUROPE?

Jason Power, Market Development Manager, Dolby Laboratories

HDTV with high resolution images and surround sound, already on air in the US, Japan, and Australia, is beginning to make its mark in Europe. European programme makers are already using HD tools for production, with high profile events such as the Athens Olympics plus numerous dramas, documentaries, and concerts being produced in HD. Until recently, however, European viewers had no means of enjoying this content in glorious HD in their own homes.

Things are now starting to change. Following on from the launch of Europe's first HD channel by Euro1080 and the HD broadcast of the Superbowl by Premiere earlier this year, German broadcaster, ProSieben, took another major step on 14 October with their transmission of *Pride – The Law of the Savannah*. This made ProSieben one of the first existing major European broadcasters to make a public HD broadcast and to simulcast for both HD and SD viewers. The programme, co-produced by the BBC, was delivered in Dolby Digital 5.1-channel surround sound, helping transport viewers into the stunning HD landscapes of the savannah.

With prices of flat panel screens falling, European consumers have the opportunity to take the step to HD far more affordably than their early adopter counterparts in the US and Australia did just a few years ago. The increasing availability and affordability of these flat displays means the European consumer is now far more willing to have bigger screens in his home. The widespread adoption of DVD has set an expectation for high quality, widescreen picture with excellent surround sound audio – so broadcasters now need to deliver something extra to challenge DVD's supremacy.

Jason Power is Market Development Manager at Dolby Laboratories, and plays a key role in marketing Dolby technologies for Digital Cinema and Digital TV. In addition to his work with cinemas and film studios, Jason works closely with broadcasters to encourage the use of high quality surround audio within the industry.



In the US, the shift to HDTV introduced many new benefits for home viewers, as analogue TV was just 4:3 and not widescreen, and audio did not include Dolby Digital. In Europe, however, a number of territories already have widescreen, and some premium channels are already delivering Dolby Digital, meaning that consumers have become accustomed to these elements, and that HD offers fewer new attractions. But with large screen availability increasing, HDTV still has a role for those broadcasters who want to capture the imagination of a high value market and to show technical leadership. Forthcoming events like the 2006 Football World Cup will provide fantastic opportunities to demonstrate HD and to persuade viewers to invest.

MPEG-2 is a technology which is understood and available for those who want to deliver HDTV now. This codec is featured in all three HDTV broadcast systems used worldwide and is already in use for Europe's first regular HDTV service, Euro 1080.

Looking forward, any next generation video codec will need coding efficiency, an open standard source code, and backwards compatibility to allow for lower definition levels with existing displays and home theatres. Establishing both the intellectual property situation and royalty situations is also an important factor. Good progress is being made in all these areas and codecs such as H.264/AVC will make HDTV delivery even easier.

However, it is important that broadcasters remember that the HDTV experience is not just about a high quality picture. Don't forget the audio/sound is critical to the experience, as without surround sound audiences feel less immersed and involved in the programming and lose the cinematic feel. The value of sound was

confirmed recently in a survey by German satellite channel, Premiere, which confirmed that Dolby Digital sound and 16:9 pictures were the top reasons why subscribers bought Pay-Per-View content.

In terms of audio, Dolby Digital is the only audio stream that broadcasters need to transmit with an HD service, as ProSieben did in October. There is no need to simulcast stereo, as all HD set-top boxes have a Dolby Digital stereo decoder, meaning the available bandwidth can be used to its full advantage to transmit the HD picture. Full guidelines for the use of Dolby Digital audio, also known as AC-3, in a DVB compliant stream are included in the relevant DVB documents (see ETSI TR101154). Dolby Digital Plus, an enhanced version of the technology for partnering with next generation video codecs, is currently being considered for future inclusion.

Broadcasters are often surprised how much HD content is already available with 5.1 surround soundtracks. 5.1 sound is increasingly created for European programming, either for transmission on digital SD services, for release on DVD, or for delivery to co-production partners in the US and elsewhere. Those importing HD programming from the US will find a wide choice of content with full 5.1 sound, as more than two dozen US channels are delivering selected programming with Dolby Digital sound – sports, award ceremonies, and various TV series are all available in HD.

For broadcasters looking to deliver that something extra to retain audience share, HD can deliver a visual feast, but to keep it competitive with today's DVD experience, 5.1 surround sound audio must be provided too.



A CHOICE OF FUTURES

In My Opinion - Alain Chaptal

Alain Chaptal holds an advanced degree in Telecommunications Engineering from Telecom Paris and a Ph.D. in Information and Communication Sciences from Université Paris X. He covers technology issues for Sonovision (www.sonovision.com), the leading French monthly magazine (circulation 15,000) dedicated to providing French speaking professionals with the latest information on audio, video, TV, graphics and multimedia.

The history of technical innovation in television broadcast is highlighted by only a limited number of major breakthroughs. The latest revolution dates back to 1990 with the first American digital HDTV proposal, the Digicipher, which surprised Europe, then engaged in an overcautious approach, opting for a transitional standard, the D2 Mac and its HD version.

However, Europe was able to react quickly through the DVB by offering an MPEG-2 –based satellite standard in 1994. More frequently however, significant technological reassessments allow us to reorient our perspective and provide ourselves with a renewed dynamic that can be the catalyst for major evolutions. This is currently the case with advanced video compression solutions and the prospects they offer for broadcasting digital television on an extensive range of media.

There has been a recent convergence between, on the one hand, consumers' increasing infatuation with widescreen in the 16/9¹ format and the image quality

decoders and is in a position to leap a technological generation, entailing a strategic advantage clearly identified in the September 2004 report of the General Information Technology Council submitted to the Minister of State for Industry.

When the DTT launch schedule is confirmed, the Government will then be faced with a strategic choice which affects the technological future of the

When these lines are drawn, the choice will not be definitively made. It appears quite recently that there was a consensus around a qualified scenario in an official report (prudent and pragmatic) which, whilst observing the initial schedule, would favour the H.264/AVC, HDTV and, in terms of the future, mobility. Clearly the launch would take place in March 2005, although it would be in two

“This scenario would allow a gentle transition towards HDTV...”

offered by DVD (pending its next HD versions) and, on the other hand, industrial product/system ranges offering HD equipment enabling a highly flexible migration at a cost increasingly on a level with SD products. The last IBC clearly reflected the industry's mobilisation with announcements of HD European satellite services (BskyB, Premiere, TPS STAR), the major presence of H.264/AVC solutions and the interest in the ultimate satellite standard DVB-S2. There is certainly a feeling that the various players concerned are on their starting blocks, regardless of the fact that Europe is currently suffering from not having outlined the path as clearly as the USA.

Strangely, as a result of these technical reorientations, France has found itself in a unique position on this world market, of which it could take advantage. With a late launch of DTT, it is not encumbered by a mountain of current MPEG-2 standard

sector for the next ten years or so.

Either it grabs this opportunity to enable the emergence of HD in DTT with the aid of the H.264/AVC at the risk of slightly altering its launch date: a choice which comprises the risks of technological innovation but which opens up promising prospects not only for the technical operators and the rest of industry, but also, first and foremost, for the content producers and thus the expression of French speaking culture. Or it consolidates the initial project and the cautious recourse to the transitional standard which has become an MPEG-2, of which the technological lifespan on a world scale will then depend primarily on the base installed, and as a result, place France, on a long-term basis, in a technologically backward situation from which it will be difficult to escape. We already know the consequences, in terms of DTT, of such a head-in-the-sand policy towards this technological leap forward.

phases: an initial pre-deployment phase geared towards technical confirmation, followed in September 2005 by the operational phase with 'multilingual' decoders (MPEG-2 SD, H.264/AVC SD and HD). The channels adopted would be free to choose their encoding mode in the initial stage. This scenario would allow a gentle transition towards HDTV but would be significantly decisive from the viewpoint of equality of access to it because, in France, approximately three quarters of television viewers receive television solely via terrestrial broadcasting.

Note: A late announcement on 8 November by the Prime Minister did confirm the launch in March of free SD channels in MPEG-2 whilst announcing the study of an HD introduction strategy with a 'final' decision before the end of the year. Does this leave the door open? Only for pay TV channels? The future remains uncertain.

¹Although the current quality of a number of LCD or plasma screens is subject to much discussion, cf. EBU Technical Review No. 298 April 2004.

DTT Is the fastest growing digital platform in Europe, but...

IS IT FAST ENOUGH?

Alexander Shulzycki,
Senior Media Analyst, EBU



Two years ago all was doom and gloom about the prospects for DTT as the pay platforms went belly up, but today DTT is the fastest growing digital platform in Europe as sales boom in the UK and Italy and steady progress continues elsewhere.

Why the turnaround? Let's look at the facts first. Seven countries now have fully launched (see chart) DTT platforms with widespread coverage, strong channel offers, and competitive set-topbox markets. About five and a half million TV households have DTT. Italy has come out of the starting block this year with the best performing DTT launch in Europe to date. Good news continues to come out of the UK with 3.9 million DTT household as of the second quarter of this year. In Germany, building on the Berlin success, the regional rollout continues in North Rhine Westphalia and other Northern areas, adding 200,000 households to the German DTT tally. Finland has made steady progress and now has the highest DTT penetration of TV households

(about 17 percent). Spain is poised for tremendous growth next year as frequencies are reallocated there. Also next year, perhaps in March, France will launch its platform and thus trigger an important milestone: the majority of Western European (EU-15) countries will have up and running DTT platforms. Very few would have predicted this two years ago.

There are three factors that have driven this change of fortune. First, a clear and viable framework set up by regulators; second, a strong and well funded Public Service Broadcaster; and lastly a platform based on a predominantly free offer. The most successful DTT markets have been those which have put these elements in place. This is a proven model and

“Guidance, coordination and support is necessary and governments across Europe have found ways to provide that support ...”

consumers have responded.

The risk now is to become overly optimistic. There are many challenges ahead, not least of which is to get all countries fully launched. It is clear that the market itself will not spontaneously create a DTT platform and move it steadily towards analogue shut off. Guidance, coordination and support is necessary and governments across Europe have found ways to provide that support through indirect financial mechanisms without violating the principle of platform neutrality. There are complaints now before the European Commission challenging some of those supports and this could

dampen DTT progress.

There are specific challenges as well for Eastern European countries, small countries without a lot of indigenous channels, heavily cabled markets, and geographically challenged countries, where mountainous regions make universal coverage financially prohibitive.

Meanwhile, analogue shut off is being seriously discussed. Right now the more or less official analogue shut off dates range from 2006 to 2012 in Western Europe, but few countries are in a position to make realistic planning. After all, if you haven't even launched, how can you reasonably judge the rate of penetration, its change over time, and when it will get you to 80 or 90 percent of TV

households? An overly aggressive shut off date is dangerous for many reasons. For those countries that are most advanced in household penetration, planning is underway and it will be very illustrative to follow their developments.

In the end, the unique benefits of DTT for policy makers, regulators, competition authorities are too strong to hold the technology back: efficient use of spectrum and release of analogue frequencies; stronger competition in the electronic communications; contribution to Information Society objectives; diversity and digital access for a wider range of the population, etc. These benefits translate directly into more and better television for consumers.

DTT Households (thousands) and Penetration

	1998	1999	2000	2001	2002	2003	2004	2004	Penetration
						1Q	1Q	2Q	
UK	247	552	774	1,217	1,260	1,400	3,000	3,900	16.3%
Sweden		15	35	83	100	140	200	270	6.6%
Spain			3	150	150	130	130	130	1.0%
Finland				5	10	97	300	400	17.4%
Germany						120	170	200	0.6%
Netherlands						3	12	40	0.6%
Italy							25	400	1.9%
TOTAL	247	567	812	1,455	1,520	1,890	3,837	5,340	

TOTAL

Source: EBU estimates

Alexander Shulzycki is a Senior Media Analyst at the European Broadcasting Union specialising in the areas of digital and pay television, audience research methods and analysis of regulation impact on broadcasters. Prior to this he was at Canal+ where he worked on the launch and operation of DTH platforms in Poland and other non French territories. He holds a BA in History and Economics from Cornell University and an MBA Finance from University of Wisconsin.

DIGITAL PARADISE



Amoordalingum Pather
CEO of Multi Carrier (Mauritius) Limited (MCML)

The small island of Mauritius (population 1.2 m) is focusing on technology to help create an environment of excellence. The target is to make ICT (Information & Communication Technology) the fifth pillar of the economy next to sugar, textiles, tourism and financial services. The country has a strong telecommunication infrastructure and has created a 'Cyber City' that is a state-of-the-art facility providing computing on demand, an Internet data centre to back up data and servers for web hosting, e-commerce and financial transactions. It will also provide a world class telecommunications network, through both satellite and the fibre optic cable that links Portugal and Malaysia via South Africa and Mauritius.

Digital Terrestrial Television (DTT), together with the MHP, has the potential to provide interactive services such as T-government, T-education and T-commerce and digital convergence can go a long way towards stimulating the national economy, informing and educating while providing greater transparency and civic participation.

Industry pundits have been predicting the convergence of IT, telecommunications and broadcast technologies and this is becoming a reality in Mauritius. The government has adopted a rational and structured approach to implement digital terrestrial television to provide multi-layer services that will help to create a wireless broadband society.

In 1998 a feasibility study and frequency planning for two initial digital multiplexes to cover the entire island was carried out with the assistance of Télédiffusion de France (TDF). This led to the pilot testing of

the DVB-T platform being carried out in 2001-02 and resulted in a report to the National Digital Broadcasting Committee (NDBC) in September 2002. The report recommended the adoption of DVB for the Republic of Mauritius and that the national broadcast transmission company Multi Carrier (Mauritius) Limited (MCML) carry out the installation of a permanent digital head-end and a DVB-T platform to provide 70 percent coverage of the



Inside Cyber City

islands with an analogue switch off date tentatively scheduled for ten years from the launch of DTT. A soft launch of DTT with interactive services is scheduled before the end of 2004 and an extension of the coverage to 90 percent is to follow. There are also plans for additional multiplexes (MFN / SFN) for datacasting, Pay-TV, T-services, mobile reception, etc., underway.

Additional tests for Pay-TV and value added services are already planned for the months to come and are as follows: CAS enabled STBs; MHP; DVB-RCT using either the 2.4 MHz or the UHF TV broadcast frequencies for a wireless return path; an all-in-one prototype STB with PVR to receive multichannel TV, Internet and online services using a wireless return path; display of electronic billboards, LCDs and plasmas with adverts and social messages and mobile reception, etc.

However, there are still some strategic issues that need to be dealt with in order to guarantee a successful take off and continuation of DTT and to enable consumers to benefit from the new technology at an affordable price. Some of these issues are: licences to prospective operators by the IBA (Independent Broadcasting Authority), operators to agree on a common CA; sharing of frequencies with a neighbouring island; availability of a scalable STB at a reasonable price; sourcing/procurement of quality content; local content creation for multimedia services; and design of specific walled gardens to cater for the Mauritian needs.

On 12 March 2003, MCML began transmissions of five digital TV channels, two CD quality radio channels and a few services on demand co-existing with the current five analogue TV channels. STBs from Europe, South Korea, India and China were tested and evaluated.

The success of digital terrestrial television demands commitment by all stakeholders concerned. Mauritius, a cyber island to be, is prepared to take full advantage of digitalisation. The MCML DVB-T platform will reinforce the role of television as an important tool of interaction in the daily life of the people to bridge the digital divide.



Amoordalingum Pather is the CEO of Multi Carrier (Mauritius) Limited (MCML) and a certified BBC Engineer. An engineer graduate scholar of the Confederation of British Industries, he is a veteran in the field of broadcasting since 1964 and holds an MBA from the University of Surrey, UK.



ANYTHING YOU CAN DO...

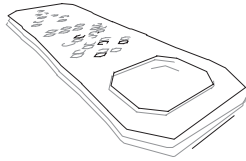

DVB member ADB (Advanced Digital Broadcast), a leading supplier of digital set-top boxes and software solutions for interactive television, has introduced the i-CAN170T, its first Integrated TV (IDTV) with MHP. Production of the i-CAN 170T started in October this year and is now on sale in Italy. It is set to become available in other European countries that have adopted MHP.

With the growing trend for flat panel screens and sole devices providing multiple services, ADB has responded by designing an LCD TV integrated with all the capabilities of a complete digital terrestrial MHP receiver, and which can be connected to a PC to display images in a 1280 X 1024 resolution through one of its digital video inputs. TV and PC signals can be displayed simultaneously in onscreen windows through its advanced PIP (picture in picture) feature.

Multifunctional with minimal space requirement, the i-CAN 170T is equipped with built in loudspeakers and a complete range of interfaces, including outputs for Home Cinema,

V.92 modem, Ethernet to ADSL port, and security facilities for providing access to personalised services. It integrates MHP 1.0.x implementation from Osmosys and its digital core is powered by the STMicroelectronics STi5517 single chip processor. The TV also includes a software loader for remote upgrades ensuring that it remains compatible with future broadcast demands.

ADB has also announced the shipment of its 500,000th interactive STB into the Italian market. The receivers are compliant with the requirements of the DGTVi the Association for the development of the digital terrestrial TV. The STBs are marketed through retail distribution channels under several national and international consumer brands.

ADB began supporting major broadcasters such as RAI, Mediaset and Telecom Italy in the Spring of 2002 with interactive home entertainment technologies for consumers. Since then, ADB's commitment to the Italian market has persevered with a growing number of partnerships

including operators, infrastructure equipment suppliers, application developers, and distribution partners.

Since the launch of the digital terrestrial service in Italy last December, ADB has introduced to the retail market its i-CAN 3000T model and, most recently, the i-CAN 2000T. Both STBs have been engineered in Europe, at ADB's R & D center in Poland, and are powered by STMicroelectronics' processors with interactivity provided by Osmosys.

"We began manufacturing in mass volume last November, ahead of the effective launch of the broadcasting services", says Philippe Lambinet, Chief Operating Officer at ADB.

"In less than one year, ADB and its distribution partners have achieved a major market share thanks to an early and firm commitment for a successful launch of digital terrestrial TV in Italy.

We are very proud of this achievement and we will continue to deliver our best efforts to advancing interactive digital terrestrial consumer technology and home entertainment services in the country."



A SMART SHOW OFFER

In 2005, take the opportunity to exhibit in the DVB Pavilion at any or all three major trade shows to demonstrate DVB technologies and services. Joining forces with DVB will significantly reduce the cost of participating in these leading industry events whilst increasing exposure. In 2004 the DVB Pavilions were visited by a constant stream of member and non-member trade show visitors.

Anyone interested in participating on the DVB Pavilion at IBC, NAB, and/or Broadcast Asia should contact Eoghan O'Sullivan in the DVB Project Office: osullivan@dvb.org.

DVB WORLD 'FROM HD TO HANDHELD'

Preparations are well under way for the next DVB World conference being held once again in Dublin at Jurys Ballsbridge and Towers Hotel from 2 – 4 March, 2005. Presented by the International Academy of Broadcasting, DVB World is one of the best opportunities to get the latest updates on technical, legal, commercial and implementation aspects of DVB.

The organisers have recently announced the conference programme and the theme of this year's event is 'From HD to Handheld'. Other topics high on the agenda include: PVRs, broadband, digital

rights management, new AVC guidelines, home networking, portable content formats, DVB business models and UMTS. Details on registration, hotels and the conference programme can be found on the IAB website: www.iab.ch.

DVB World 2005 provides the only opportunity to receive a direct briefing from DVB Chairs and the world's leading experts.

The organiser's office are reporting that delegates have already begun to register and as anyone who attended the conference last year will know it was a sell out event, so don't delay as participation is limited.

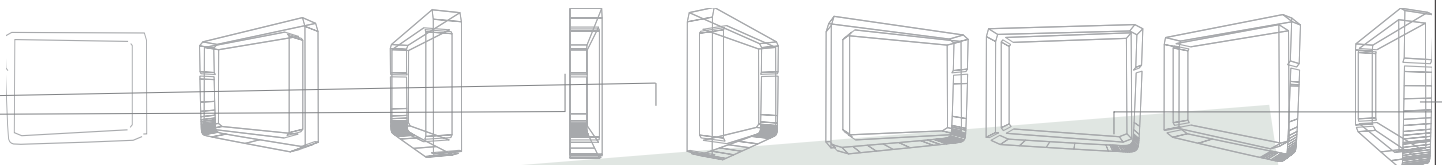

FUTURECOM

Furthering its commitment to the Brazilian and Latin American broadcasting and telecommunication industries, DVB participated at the recent Futurecom in Florianopolis, Brazil with a number of activities designed to demonstrate the technological and economic advantages of its globally successful open standards for digital broadcast services including DVB-H, the exciting new specification that combines the excellent mobile performance of DVB-T with IP datacasting technology extending the range of DVB-T services into the mobile handset market.

In an opener to the main conference and exhibition, DVB took part in a well attended pre-conference workshop on the DVB-RCS (Return Channel Satellite) interactive satellite standard sponsored by ETSI under the @LIS programme.



DVB WORLD 2005

‘From HD to Handheld’

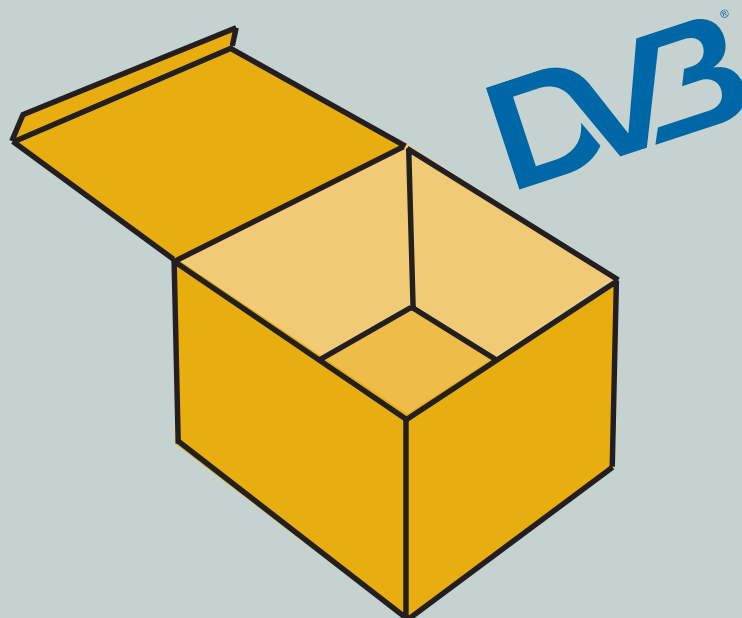

Mark a date in your diary now...
2 – 4 March, 2005 – Dublin, Ireland

For further information visit the DVB & IAB
websites: www.dvb.org – www.iab.ch

