

ALLEN & HEATH



WARNING – HIGH VOLTAGES

Power Supply Unit (PSU) work should only be carried out by qualified personnel.

We recommend that you use an approved Allen & Heath service centre for all power supply work.

Please contact your local Allen & Heath distributor for more details.

<http://www.allen-heath.com/>



MixWizard Series

WZ20S

Stereo Audio Mixing Console

SERVICE MANUAL

Publication No: AP3638

CONTENTS

INTRODUCTION, SERVICE AND TECHNICAL SUPPORT.....	3
FLIGHTCASING THE CONSOLE & DIMENSIONS	4
SPECIFICATIONS & CONNECTIONS	5
ORDERING A MIXWIZARD WZ20S UNIT, OPTIONS & MANUALS	6
ORDERING SPARE ASSEMBLIES.....	6
ORDERING SPARE PARTS.....	7-8
MONO INPUT BOARD COMPONENT IDENT	AG3379
MONO INPUT BOARD CIRCUIT DIAGRAM.....	C3379
STEREO INPUT BOARD COMPONENT IDENT	AG3408
STEREO INPUT BOARD CIRCUIT DIAGRAM	C3408
LEFT BOARD COMPONENT IDENT	AG3627
LEFT BOARD CIRCUIT DIAGRAM (PAGE 1 OF 2).....	C3627
LEFT BOARD CIRCUIT DIAGRAM (PAGE 2 OF 2).....	C3627
RIGHT BOARD COMPONENT IDENT.....	AG3626
RIGHT BOARD CONNECTOR CIRCUIT DIAGRAM (PAGE 1 OF 2).....	C3626
RIGHT BOARD CONNECTOR CIRCUIT DIAGRAM (PAGE 2 OF 2).....	C3626
CONNECTOR BOARD COMPONENT IDENT.....	AG3632
CONNECTOR BOARD CIRCUIT DIAGRAM (PAGE 1 OF 3).....	C3632
CONNECTOR BOARD CIRCUIT DIAGRAM (PAGE 2 OF 3).....	C3632
CONNECTOR BOARD CIRCUIT DIAGRAM (PAGE 3 OF 3).....	C3632

Warning to the Service Engineer

Allen & Heath warns that any unauthorised changes or modifications to the **WZ20S** unit may invalidate the legal compliance of the unit and could void the user's authority to operate the equipment.

WZ20S Service Manual AP3638 Issue 2. Copyright © 2005 Allen & Heath. All rights reserved

MANUFACTURED IN ENGLAND BY:

ALLEN&HEATH

Kernick Industrial Estate
Penryn, Cornwall, TR10 9LU. UK
<http://www.allen-heath.com>

ALLEN & HEATH AGENT:

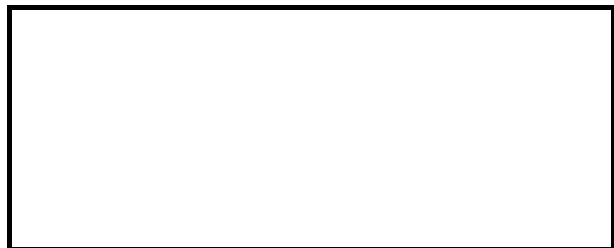

Introduction

The information presented in this manual is intended for competent technical personnel to carry out service and product support for the **MixWizard WZ20S** console. We assume that the reader is familiar with the related electronic theory and audio terminology, and is able to carry out basic servicing, faultfinding and repair of audio equipment of this type. Service personnel should also be familiar with audio systems, mains earthing and power requirements, as well as handling precautions.

For information on the configuration, operation and application of the *MixWizard WZ20S* please refer to the User Guide.

Whilst we believe the information in this manual to be reliable we do not assume responsibility for inaccuracies. We also reserve the right to make changes in the interest of further product development.

Service and Technical Support

Under normal operating conditions the **MixWizard WZ20S** does not require user maintenance or internal calibration. Any service work required should be carried out by qualified technical personnel only.

We are able to offer further product support through our worldwide distribution network. To help us provide an efficient service please quote the console serial number, the date and place of purchase in any communication regarding this product.

SAFETY WARNING!

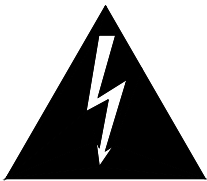

Mains electricity is dangerous and can kill. Mains voltage is present within the unit.

Do not remove the cover with mains electricity connected. To ensure your safety, mains earth is connected to the chassis through the power lead. Do not remove this mains earth connection.

To avoid the risk of fire, replace the mains fuse with the correct value and type as indicated on the rear panel.



Before switching on your console, check that the fuse is of the correct rating and type. This is clearly marked on the rear panel. Do not replace the fuse with any other type, as this could become a safety hazard and will void the warranty.

General Precautions

Your **WZ20S** is ruggedly constructed to give many years of reliable operation. However, you will extend the life of the console and preserve its cosmetics by applying these simple common sense precautions.

- Avoid storing or using the mixing console in conditions of excessive heat or cold, or in positions where it is likely to be subject to vibration, dust dirt or moisture.
- Do not use any liquids to clean the control surface of the console, a soft dry brush or dry lint-free cloth is ideal.
- Use only water or ethyl alcohol to clean the trim and scribble strips. Other solvents may cause damage to paint or plastic parts.
- The faders, switches and potentiometers are lubricated for life. The use of electrical lubricants on these parts is not recommended.
- Avoid using the console close to strong sources of electromagnetic radiation (e.g. video monitors, high power electric cabling): this may cause degradation of the audio quality due to induced voltages in connecting leads and chassis.

Flightcasing the Console

If the console is to be regularly moved we recommend that it is installed in a foam-lined flightcase. At all times avoid applying excessive force to any knobs, switches or connectors.

Dimensions for flightcasing the console are shown below:

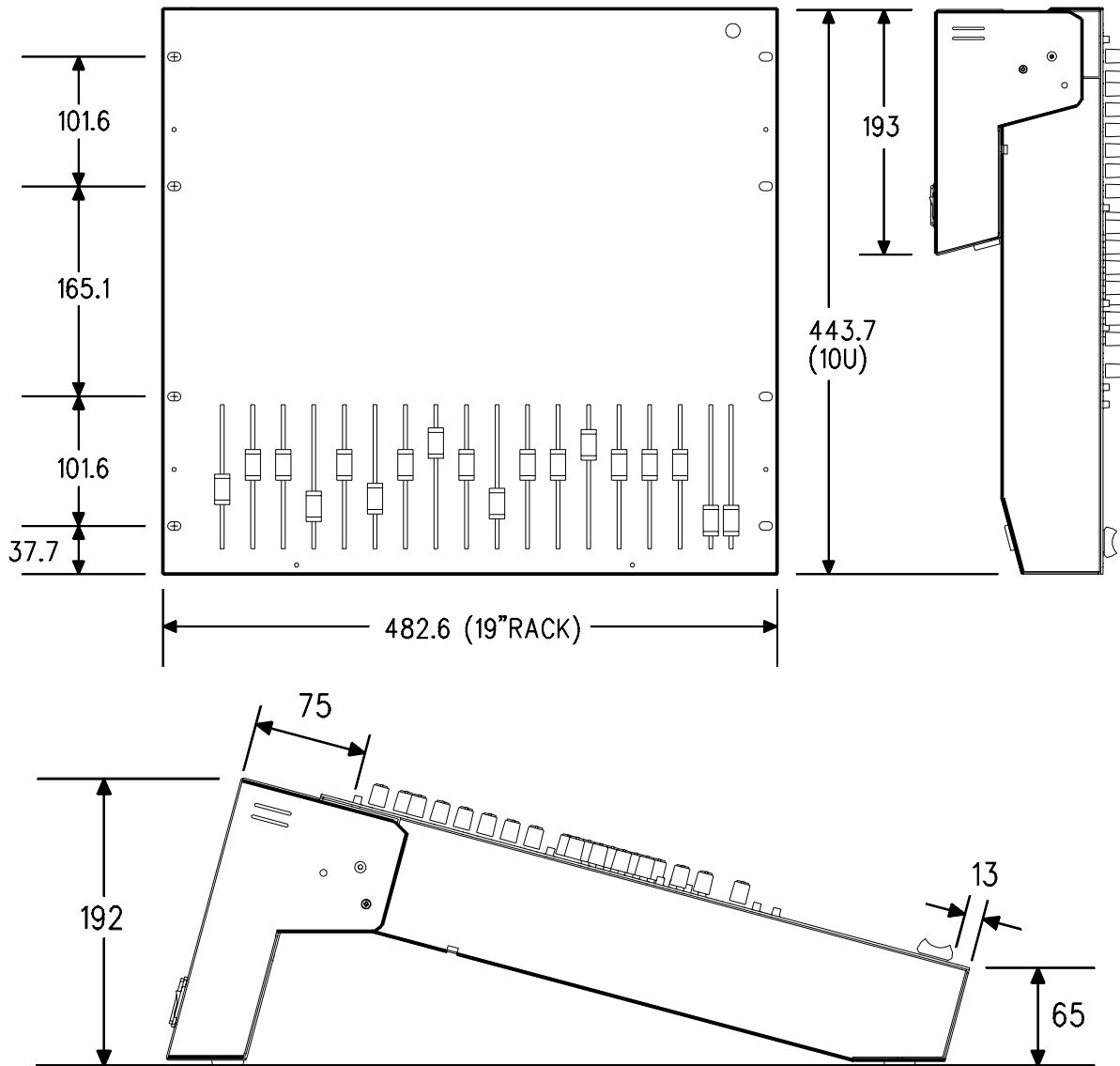

Dimensions

	Width	Height	Depth
Desktop	483mm (19")	192mm (7.6")	530mm (20.9")
Rack mounted	483mm (19")	444mm (17.5") 10U	135mm (5.3")
Packed.....	590mm (23.2")	260mm (10.2")	610mm (24")
	<u>Unpacked</u>	<u>Packed</u>	
Weight.....	10kg (22lbs)	13kg (29lbs)	

Specifications

0dBu = 0.775 Volts rms +4dBu = 1.23V rms
 0dBV = 1 Volt rms -10dBV = 316mV rms

INTERNAL HEADROOM:

..... Channels +21dB
 Mix to output +23dB

MAXIMUM OUTPUT LEVEL:

XLR +26dBu into >2k ohm load
 TRS jack +21dBu into >2k ohm load

PEAK INDICATORS: Turn on 5dB before clipping

METERS:

..... MIX 1,2 / MONITOR Peak reading 12 led 3 colour

FREQUENCY RESPONSE:

..... 20Hz to 50kHz +0/-1dB

DISTORTION: THD+noise @ +14dBu 1kHz

..... < 0.006%

CROSSTALK: Channel shutoff measured at 1kHz

..... < 90dB

NOISE: Measured rms 22Hz to 22kHz

MIC EIN: referred to 150 ohm source

..... -128dB

RESIDUAL OUTPUT NOISE:

..... XLR -90dBu (-94dB S/N)

..... TRS jack -94dBu (-94dB S/N)

MIX NOISE, CH ROUTED:

..... XLR -86dBu (-90dB S/N)

..... TRS jack -90dBu (-90dB S/N)

POWER SUPPLY:

100 to 240V AC @ 50/60Hz

Internal switch mode power unit with auto sensing mains input.

Power Consumption 35W max

Mains fuse rating 100-240VAC T500mA 20mm

Connections

INPUTS:

Mic in XLR pin 2 hot, 3 cold, balanced 2k Ohm variable -60 to -20dBu
 Line in TRS jack tip hot, ring cold, balanced >10k Ohm variable -30 to +10dBu
 Stereo Ch in A RCA PHONO unbalanced >10k Ohm variable -20 to +10dBu
 Stereo Ch in B TRS jack tip hot, ring cold balanced >10k Ohm variable -20 to +10dBu
 EXT in 1-2 TRS jack tip hot, ring cold balanced >10k Ohm variable -10dBV (+4dBu option)

OUTPUTS:

Direct out 1-4 TRS jack tip hot, ring cold, impedance balanced <75 Ohm 0dBu
 Mix out 1-2 XLR pin 2 hot, 3 cold, balanced <75 Ohm +4dBu
 Mix out 2 TRS jack tip hot, ring cold, impedance balanced <75 Ohm -2dBu
 Mono out XLR pin 2 hot, 3 cold, balanced <75 Ohm +4dBu
 Aux out 1-6 TRS jack tip hot, ring cold, impedance balanced <75 Ohm -2dBu
 Phones out 1, 2 TRS jack tip left, ring right for stereo headphones 75 to 600 Ohms

INSERTS:

Mono Channel:

Send TRS jack tip send, ring return, unbalanced <75 Ohm 0dBu

Return TRS jack tip send, ring return, unbalanced >3k Ohm

Mix out 1-2:

Send TRS jack tip send, ring return, unbalanced <75 Ohm -2dBu

Return TRS jack tip send, ring return, unbalanced >7k Ohm

ORDERING A CONSOLE

To order a new *MixWizard* console please specify the model number and AC mains voltage.

<u>MODEL</u>	<u>DESCRIPTION</u>	<u>ORDER CODE</u>
<u>MIXWIZARD WZ20S</u>	<u>4 Mono + 8 Stereo Input Channels</u>	<u>WZ20S/volts</u>

ORDERING AN OPTION

To order an option please specify the model number required.

<u>RIAA OPTION</u>	<u>WZ20S RIAA DUAL INPUT OPTION</u>	<u>W21442/20S-RIAA</u>
<u>FADER START</u>	<u>WZ20S MONO FADER START OPTION</u>	<u>002-496</u>
<u>FADER START</u>	<u>WZ20S 4M8S FADER START OPTION</u>	<u>002-501</u>

MANUALS AND SUPPORT DOCUMENTATION

<u>DESCRIPTION</u>	<u>ORDER CODE</u>
<u>MIXWIZARD WZ20S User Guide</u>	<u>AP3634</u>
<u>MIXWIZARD WZ20S Service Manual</u>	<u>AP3638</u>
<u>MIXWIZARD WZ20S Flyer</u>	<u>AP3637</u>

SERVICE TOOLS

The tools required to service the *MixWizard WZ20S* are standard to an electronics service workshop and are easily obtainable. The following items are necessary for disassembly and service access:

<u>1-point Crosshead screwdriver (M3, M4, 4AB)</u>	<u>AT0004</u>
<u>11mm AF Nutdriver (potentiometer, headphone socket and jack nuts)</u>	

ORDERING AN ASSEMBLY

The following assemblies for the *MixWizard WZ20S* are supplied fully tested. Please quote the description and order code for the part required.

Printed circuit board (PCB) assemblies:

<u>Mono Input PCB assembly</u>	<u>002-483</u>
<u>Left PCB assembly</u>	<u>002-484</u>
<u>Right PCB assembly</u>	<u>002-485</u>
<u>Stereo PCB assembly</u>	<u>002-487</u>
<u>Connector PCB assembly including Power Supply</u>	<u>002-486</u>

IDC connector harnesses:

<u>WZ20S 16 way Main harness</u>	<u>AL3669</u>
<u>WZ12/16/20S/464 34 way Master harness</u>	<u>AL3518</u>

ORDERING A SPARES KIT

It is recommended that the spares kit order code **002-491** is held and maintained by the service agent to enable in-field service repairs to the **WZ20S** independent of the ALLEN & HEATH factory. Commonly available items such as resistors, capacitors, tools and soldering equipment are not included. The contents of the kit are listed below and are supplied in a cabinet of drawers. Individual spare parts may be ordered. Please quote the description and order code for the part required.

DESCRIPTION	ORDER CODE	QTY
--------------------	-------------------	------------

Fixings:

Screw M3 x 6mm TT Pan Pozi Black	AB0071	10
Screw M3 x 8mm Pan Pozi Black	AB0073	10
Screw M3 x 10mm Pan Pozi Black	AB0076	10
Nylock Nut M3	AB0102	10
Screw M3 x 4mm Pan Pozi Black	AB0233	10
Washer M3 Shakeproof	AB0244	5
Screw 4AB x ¼ Pan Pozi Plated	AB0252	1
Screw 4 x 5/16" Poly Pan Pozi Black	AB2810	10
Screw M3 x 6mm TT CSK Pozi Black	AB2929	5
Fastfoot	AK0102	2

Knobs and caps:

Knob Red & Grey 11mm D	AJ2074	10
Knob Blue & Grey 11mm D	AJ2075	10
Knob Light Blue & Grey 11mm D	AJ2076	10
Knob Green & Grey 11mm D	AJ2077	5
Knob Dark Grey & Grey 11mm D	AJ2078	10
Knob Yellow & Grey 11mm D	AJ2079	10
Knob Brown & Grey 11m D	AJ2080	5
Button 5.5mm Square Grey	AJ2864	10
Button 10x5mm Rectangular Grey	AJ2865	5
Button Round Black	AJ2887	3
Button 5.5mm Square White	AJ2960	10
Button 5.5mm Square Red	AJ2961	10
Button 10 x 5mm Rectangular White	AJ2962	10
Switch Cap Tall	AJ8071	5
Fader Knob 11mm White+Black Line	AJ8078	5
Fader Knob 11mm Yellow+Black Line	AJ8080	5
Fader Knob 11mm Blue+Black Line	AJ8081	10

Faders, Potentiometers, Switches and connectors:

Pot 20KK (203K 11mm wide)	AI8003	10
Pot 20KB centre click (203B 11mm wide)	AI8004	10
Pot 200KC x 2 (204C 1mm wide)	AI8005	10
Pot 20KB x 2 centre click (14mm wide)	AI8006	5
Pot 20KK x 2 (203K 14mm wide)	AI8007	10
Pot 10KAC x2 (103AC 14mm wide)	AI8008	10
Pot 5K (502RD 11mm wide)	AI8111	5
Fader 10KD 100mm	AI8117	5
Fader 10KD x 2 100mm	AI8118	10
Switch 2PCO Latching 90°	AL0162	5
Jack Socket Headphone	AL0328	1
XLR 3 Pin Female Vertical PCB Mount	AL2410	3
XLR 3 Pin Male Vertical PCB Mount	AL2411	3
Phono Socket 24mm Dual Vertical PCB Mount	AL3240	5
Jack Socket ¼" Stereo Unswitched	AL3407	5
Jack Socket ¼" Stereo Switched	AL3410	5
Switch 2PCO Latching Vertical	AL8057	3
Switch 2PCO Latching 90Deg	AL8065	5
Pot Nut 9mm	AB8050	20

LEDs and Semiconductors:

Transistor BC549 NPN	AE0020	10
Transistor BC638 PNP TO92H	AE0037	5
IC TL072 Dual Op-Amp	AE0046	5
Transistor BC637 NPN TO92H	AE0068	5
IC LM339N Quad Comparator	AE0071	3
Transistor J111N FET T092B	AE0083	2
LED 3mm T1 Red	AE0086	5
IC CMOS 4053B	AE0117	5
IC Op-Amp NE5532N	AE0221	5
Transistor 2N4403 PNP	AE0273	10
IC SSM2142P Bal Out Driver	AE0302	3
LED Bar Rectangular 12 Way	AE2701	2
Transistor BC556B PNP	AE3001	5
LED Rect Green 5X2MM Flat Top	AE3501	5
LED Rect Red 5X2MM Flat Top	AE3502	2
IC TL072 Op-Amp SIL	AE8070	5
Transistor MPSA92 PNP	AE8119	1

POWER SUPPLY:

Insulation Guard	AA3509	1
Mains Lead IEC-2 Pin (Europe)	AH0205	-
Mains Lead IEC-3 Pin (UK)	AH0206	-
Mains Lead IEC-3 Pin C33 (USA)	AH0323	-
Fuseholder 20mm PCB Mount	AL3178	-
IC Opto-Isolator 4N35	AE0266	1
Diode Zener 47V 500mW	AE2999	1
Transistor TIP122	AE3215	1
Diode BYV27-400 2A	AE3469	5
Diode BYV26E 1A 1000V	AE3470	5
Diode P6KE200A	AE3471	3
Transistor Mosfet STP4NA80FI	AE3472	3
IC SMPS UC3842AN	AE3473	3
IC TL431 Voltage Reference	AE3475	1
Bridge Rectifier 2KBP04M	AE3477	2
Inductor 4.7uH 600mA	AM3467	2
Transformer Wizard Switch Mode	AM3476	1

Miscellaneous:

MixWizard Box + Fittings	AP2915	-
Flex cable 39 way 200mm	AH2900	2
Flex Socket 12 Way 90Deg	AL2226	-
Flex Socket 12 Way Straight	AL2227	-
Flex Socket 8 Way 90Deg	AL2901	-
Flex Socket 39 Way Straight	AL2902	-

3-41-2L-R PFL □N PAN /PRE A6 A5 /PRE A4 A3 A2 A1 EQ IN LF LEVEL FREQ MF2 LEVEL FREQ MF1 LEVEL FREQ HF CUT GAIN PAD PHASE

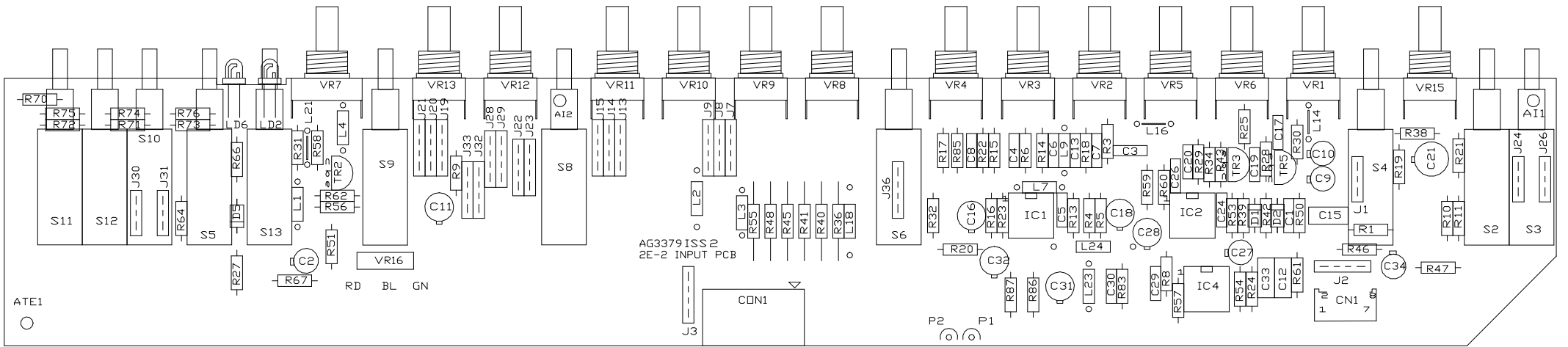

FLEXI TO
CONNECTOR POD

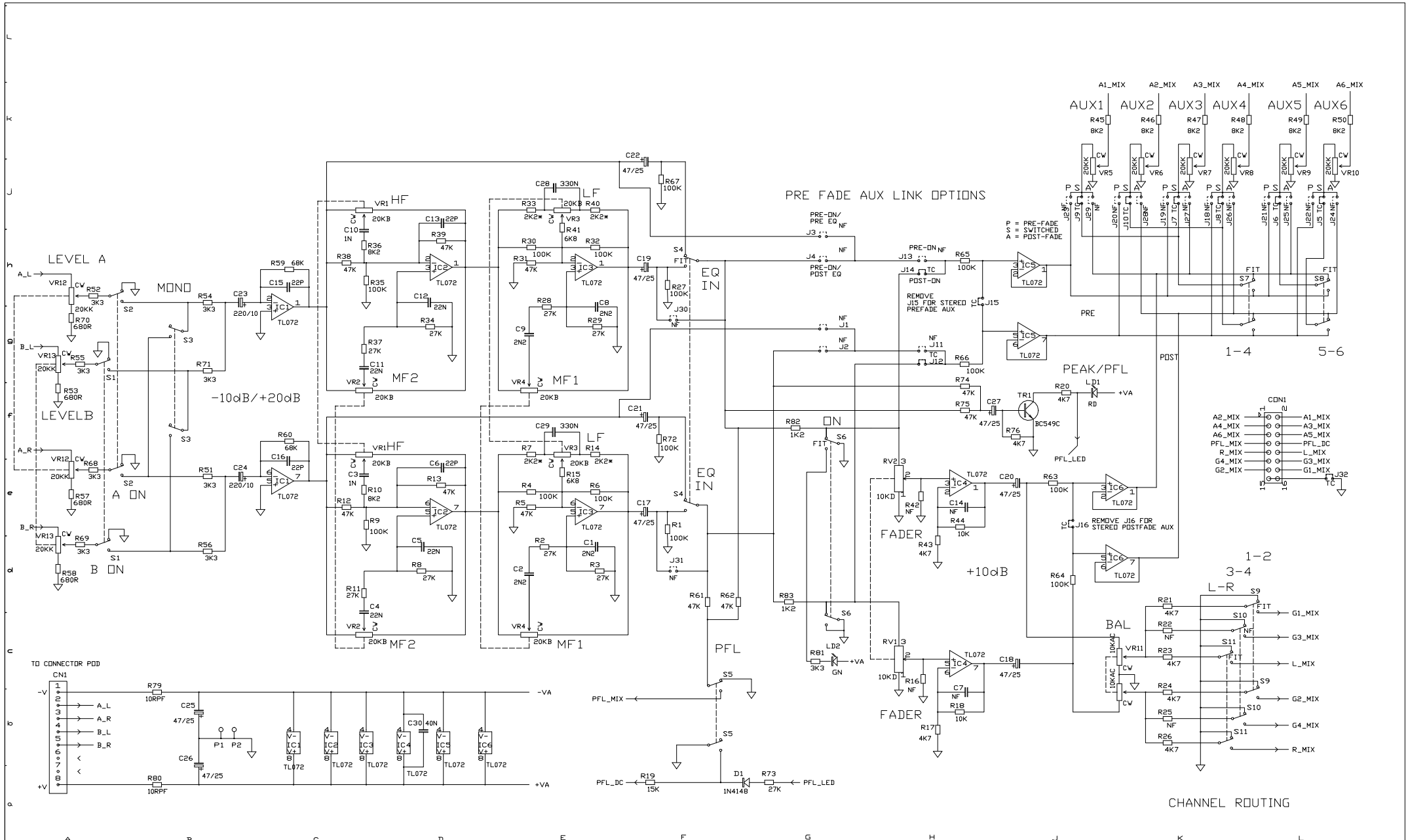

ISS.	REVISION	BY	DATE	NOTES
1	PRODUCTION	AAT	14-06-99	1. RESISTORS MARKED * ARE 1%. ALL OTHERS ARE 5% 1/4W UNLESS OTHERWISE MARKED 2. ELECTROLYTIC CAPACITORS ARE μVOLT S

FOR REFERENCE ONLY
NOT TO BE USED TO UPDATE PCB

UNIT TITLE	W2 20S STEREO		MANUFACTURED IN ENGLAND BY	ALLEN & HEATH	
DRAWING TITLE	STEREO CIRCUIT DIAGRAM		DRAWING No	3408_20S	ISSUE
		PCB TYPE	AG3408	1	A1

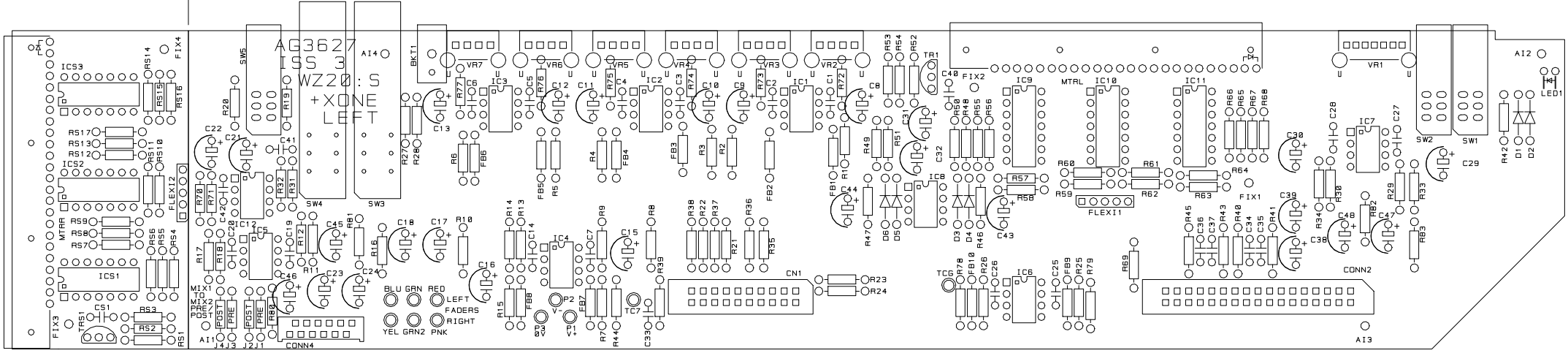

INITIAL	ISSUE	DATE
MG	3	19-8-99

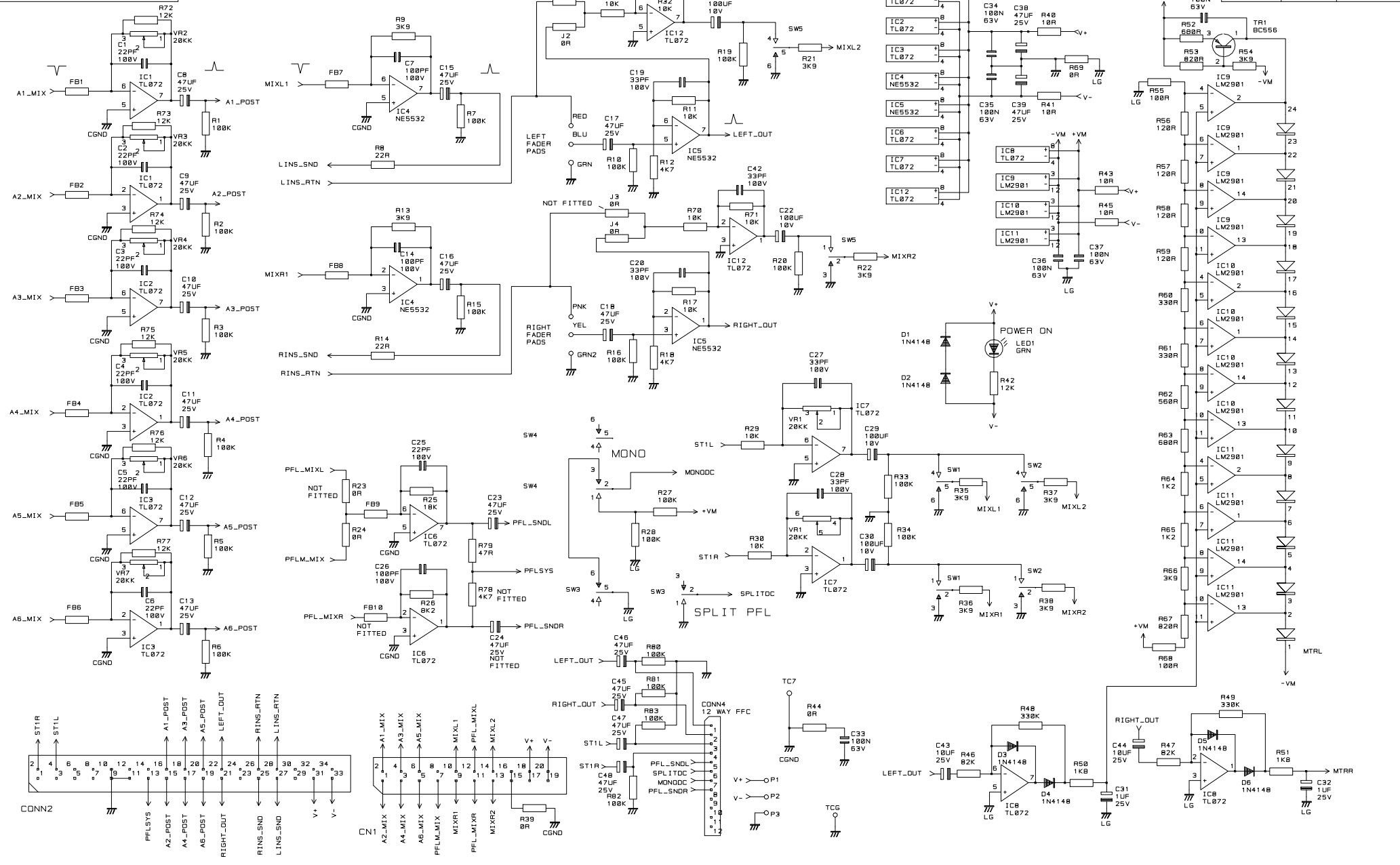

ALLEN & HEATH
 COPYRIGHT OF THIS DRAWING
 WHICH IS NOT TO BE COPIED,
 REPRODUCED OR DISCLOSED, IN PART
 OR IN WHOLE TO A THIRD PARTY
 WITHOUT WRITTEN PERMISSION.

NOTES

VR1 20K
 VR2 20K
 VR3 2x20K
 VR4 20K
 VR5 20K
 VR6 20K
 VR7 20K

POT BRACKETS CONNECTED
 TO ENFORCE CONNECTION
 TO FRONT PANEL FOR
 HUM SHIELDING

DRN. MG
 AG3627

ALLEN & HEATH
 KERNICK INDUSTRIAL EST
 PENRYN
 CORNWALL
 TR10 9LU
 TEL: 01326 372070
 FAX: 01326 377097

TITLE
 WIZARD 20: S
 MASTER LEFT PCB

DRG NO. 3627

SHT. 1 OF 2

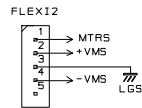
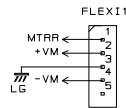
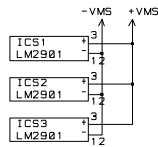
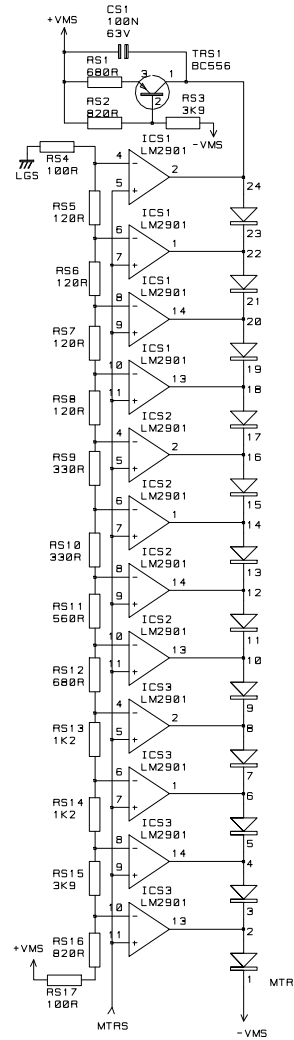

ALLEN & HEATH
 COPYRIGHT OF THIS DRAWING
 WHICH IS NOT TO BE COPIED,
 REPRODUCED OR DISCLOSED, IN PART
 OR IN WHOLE TO A THIRD PARTY
 WITHOUT WRITTEN PERMISSION.

NOTES

DRN. MG

ALLEN & HEATH
 KERNICK INDUSTRIAL EST
 PENRYN
 CORNWALL
 TR10 9LU
 TEL: 01326 372070
 FAX: 01326 377097

TITLE WIZARD 20:S
 MASTER LEFT PCB

DRG NO. 3627

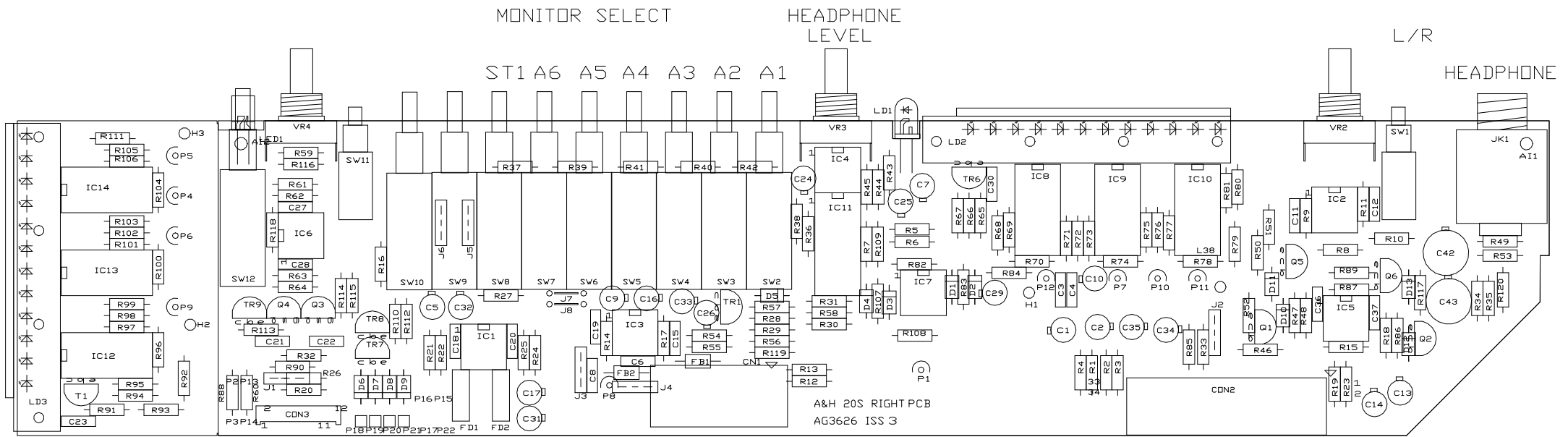

POWER SUPPLY FILTERING

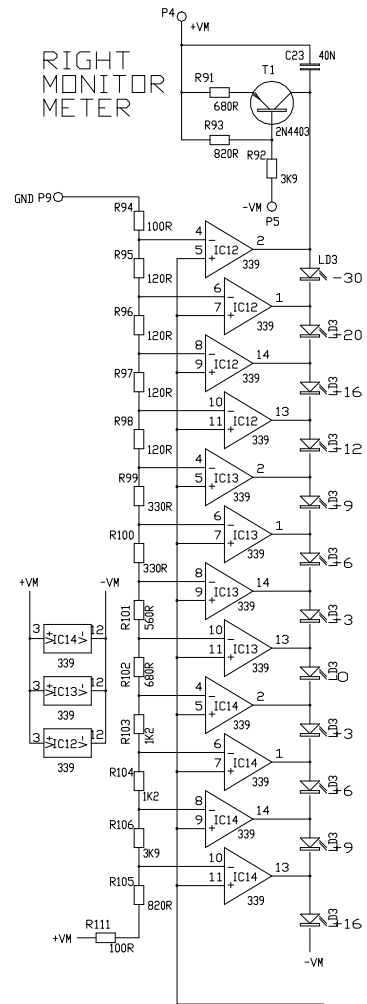
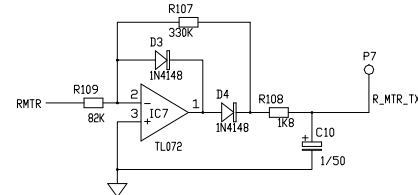
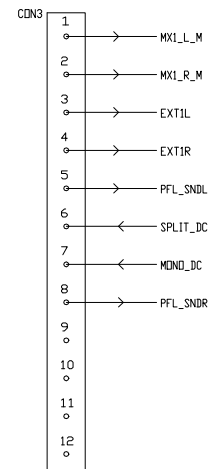
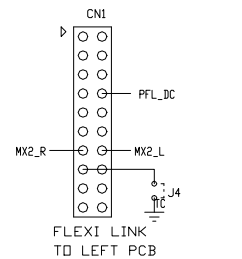
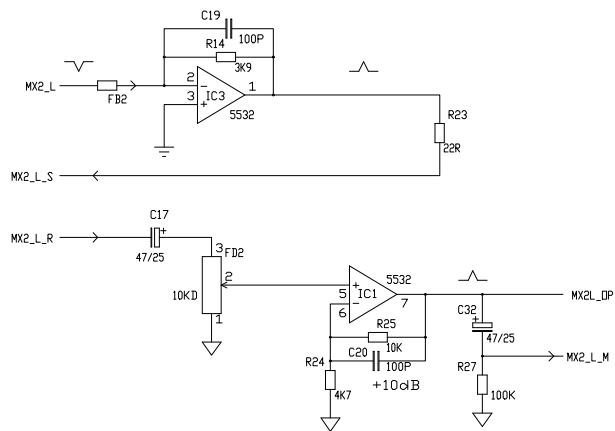
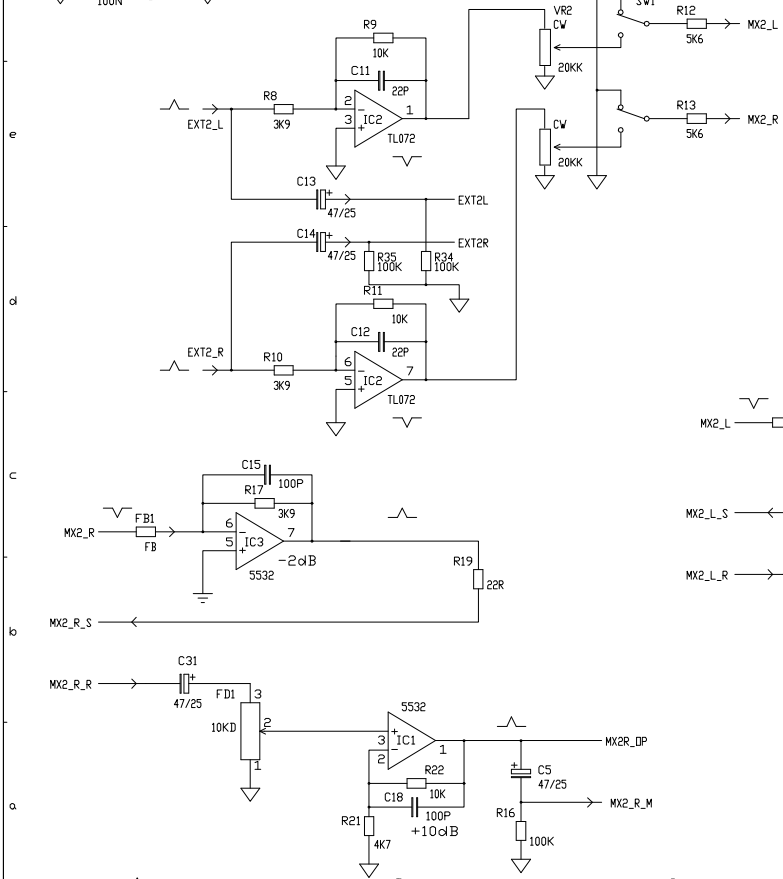
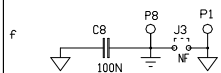
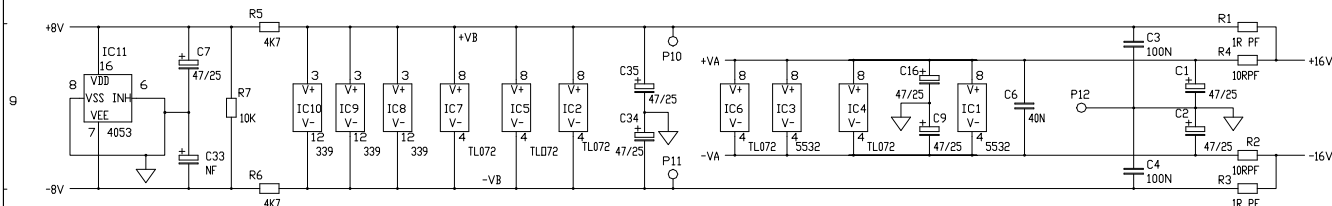

ISS.	REVISION	BY DATE	NOTES	UNIT TITLE	MANUFACTURED IN ENGLAND BY
1	PRODUCTION HEADPHONE GRND METER GROUND	AAT21-05-99 ARJ 18-8-99 AAT10-11-99	1. RESISTORS MARKED * ARE 1% ALL OTHERS ARE SZ 1/4W UNLESS OTHERWISE MARKED 2. ELECTROLYTIC CAPACITORS ARE 25V/50V	STEREO/CLUB WIZARD	ALLEN & HEATH
				DRAWING TITLE	DRAWING No.
				RIGHT PCB	ISSUE
				PCB TYPE AG3626	3
					A2

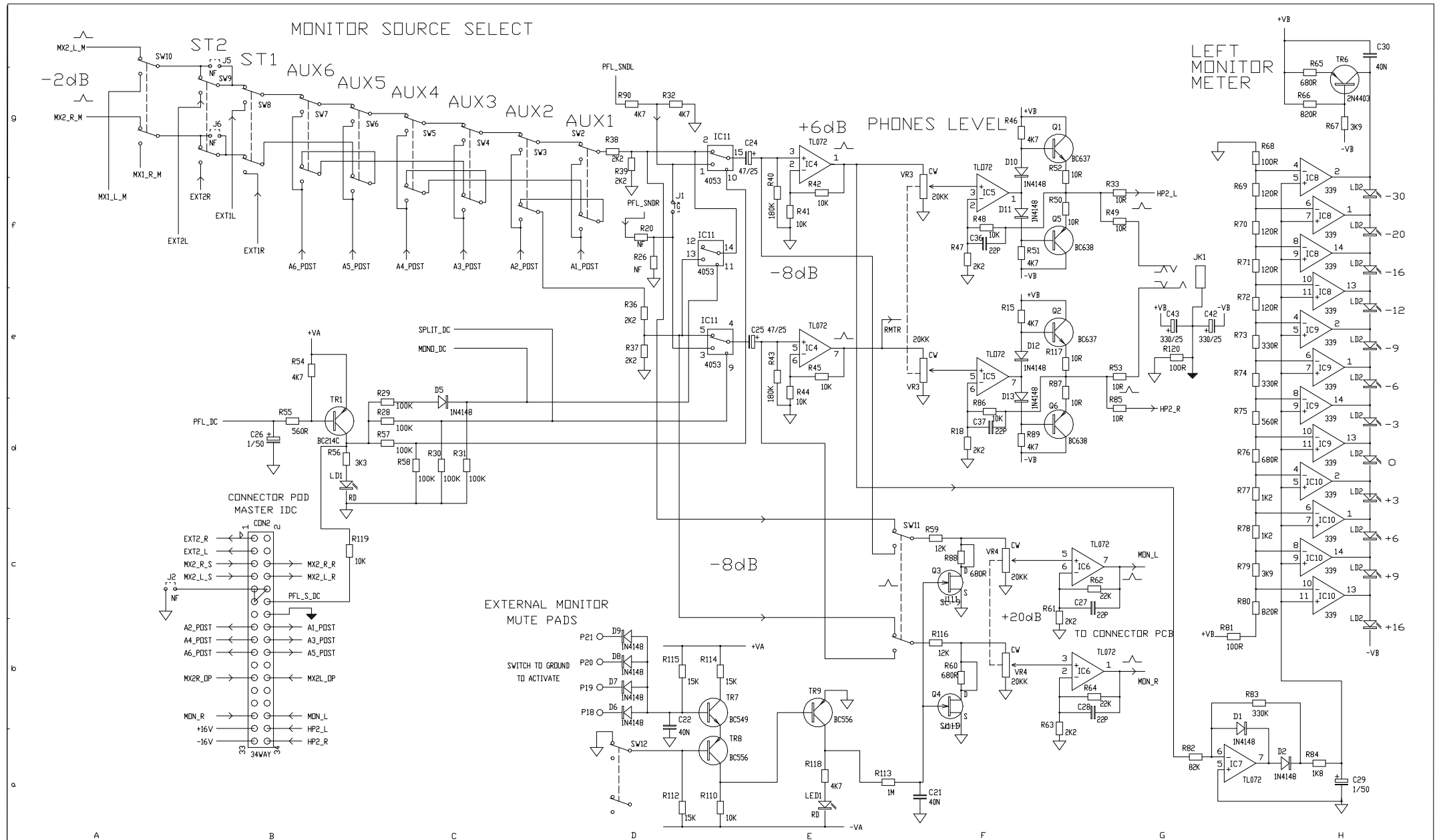

ISS. 1 301	REVISION	BY DATE	NOTES	UNIT TITLE	MANUFACTURED IN ENGLAND BY
	PRODUCTION	AAT21-05-99	1. RESISTORS MARKED * ARE 1% ALL OTHERS ARE SZ 1/4W UNLESS OTHERWISE MARKED	STEREO/CLUB WIZARD PAGE 2 OF 2	ALLEN & HEATH
	HEADPHONE GRND	ARJ 18-8-99	2. ELECTROLYTIC CAPACITORS ARE 2%VOLTS	DRAWING TITLE	
METER GROUND	AAT10-11-99			RIGHT PCB PCB TYPE AG3626	DRAWING No. C3626 ISSUE 3

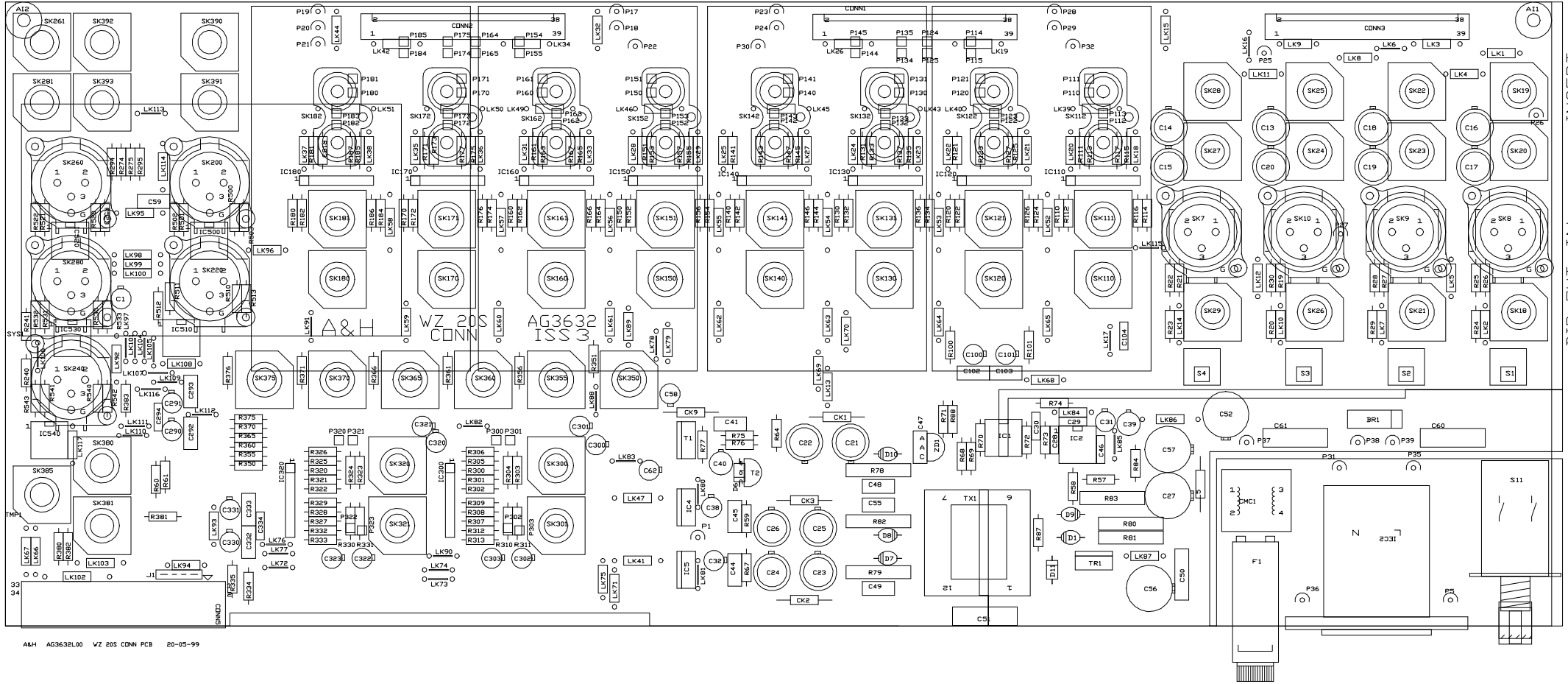

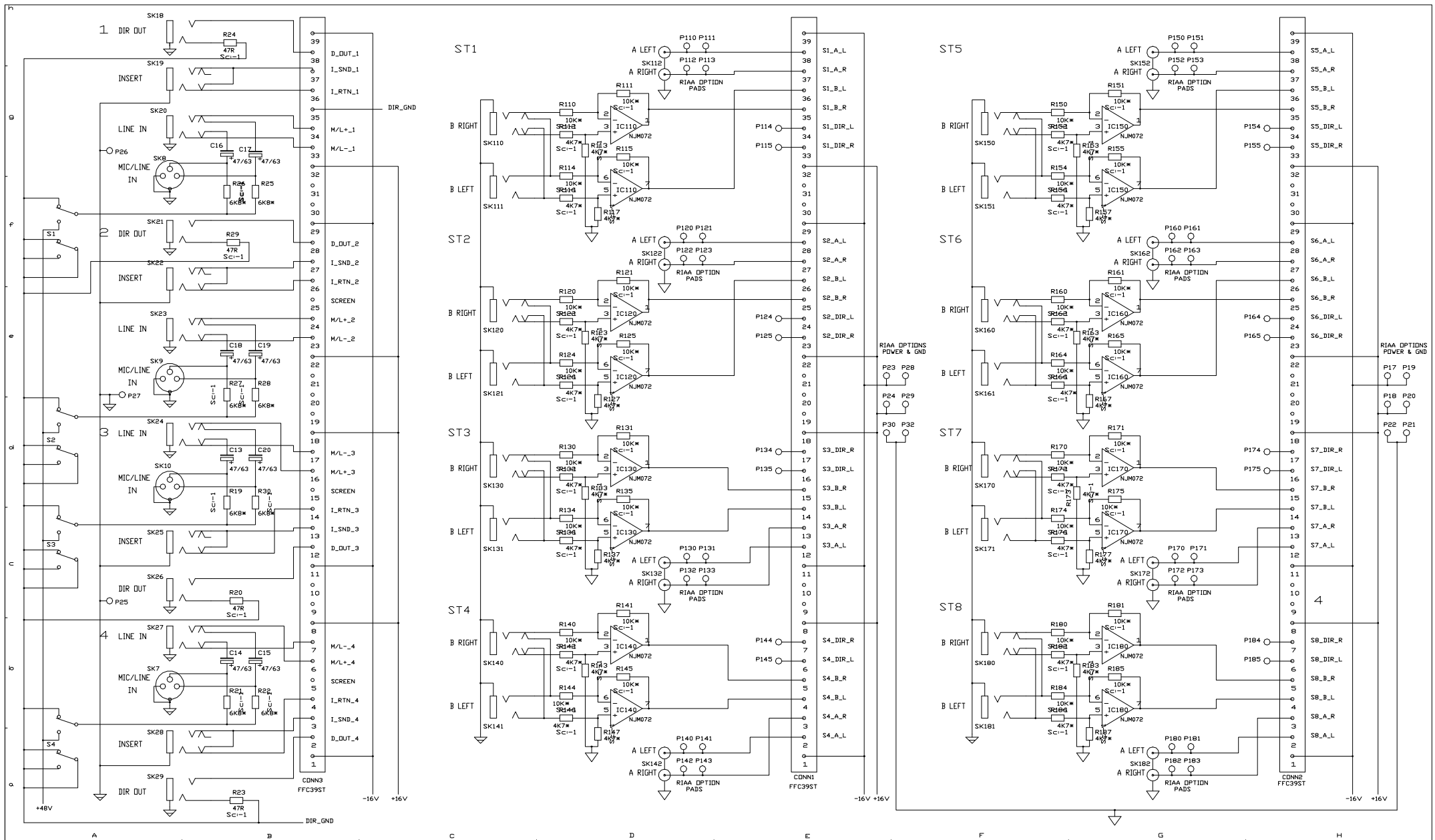

ISS.	REVISION	BY DATE	NOTES
1	PRODUCTION	AAT20-05-99	1. RESISTORS MARKED * ARE 1% ALL OTHERS ARE SZ 1/4W UNLESS OTHERWISE MARKED
2	EARTH PAD ADDED	AAT30-06-99	
2.1	NOISE PERFORMANCE	DWD27-07-99	2. ELECTROLYTIC CAPACITORS ARE 1%VOLT
3	TRACK CUT MOD.	DWD26-08-99	

UNIT TITLE
WIZARD 20 S
 DRAWING TITLE
CONNECTOR PCB
 PCB AG3401

ALLEN & HEATH
 KERNICK INDUSTRIAL ESTATE
 PENRYN
 CORNWALL
 ENGLAND TR10 9LU
 TEL. (44) (0) 1326 372070
 FAX. (44) (0) 1326 377097
 DRAWING No. **C3632** ISSUE **3** **A2**

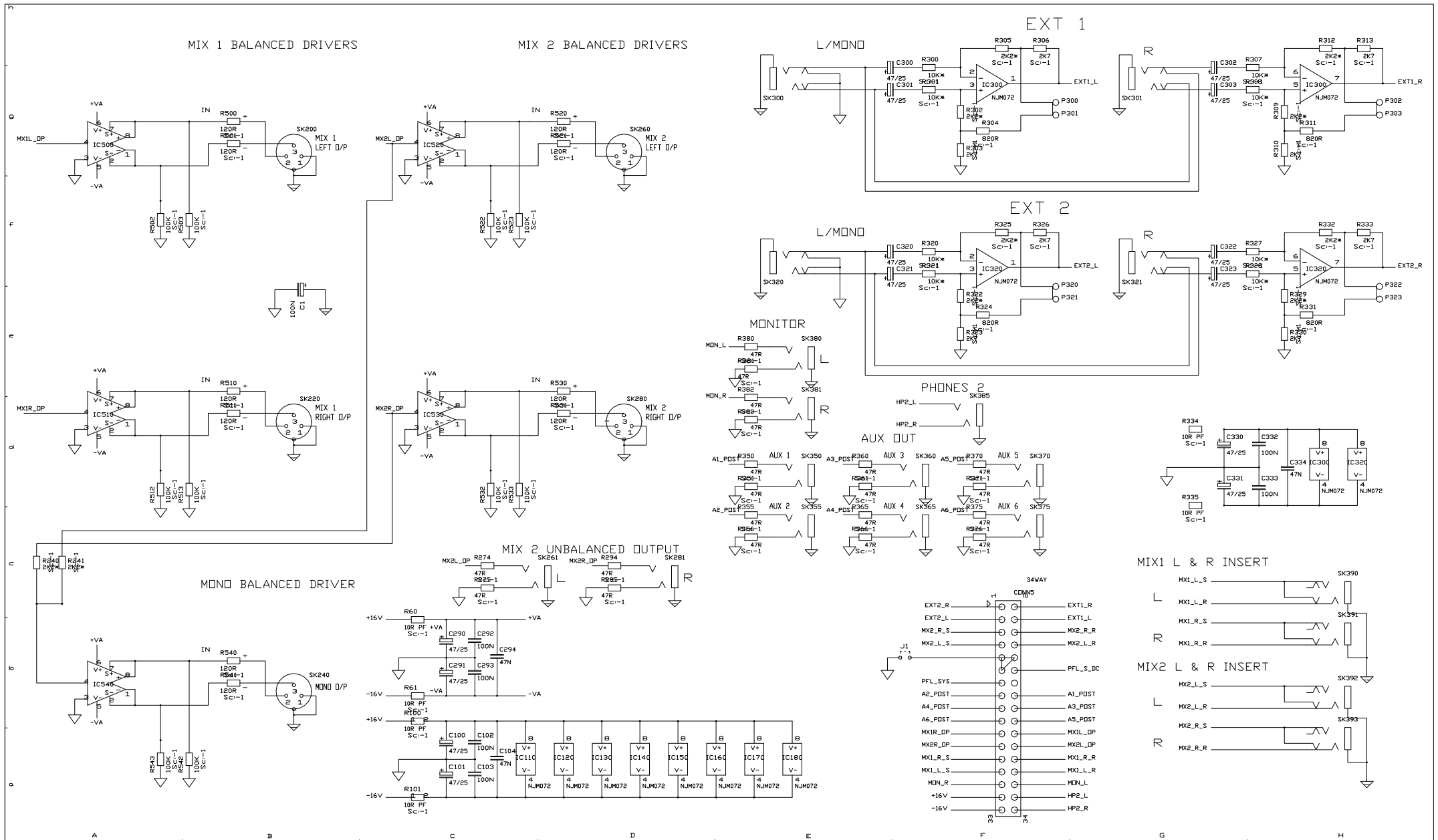

ISS.	REVISION	BY DATE	NOTES
1	PRODUCTION	AAT20-05-99	1. RESISTORS MARKED * ARE 1% ALL OTHERS ARE SZ 1/4W UNLESS OTHERWISE MARKED
2	EARTH PAD ADDED	AAT30-06-99	
2.1	NOISE PERFORMANCE	DWD27-07-99	
3	TRACK CUT MOD.	DWD26-08-99	2. ELECTROLYTIC CAPACITORS ARE 1%VOLT

UNIT TITLE
WIZARD 20 S PAGE 2 OF 3

DRAWING TITLE
CONNECTOR PCB PCB AG3401

ALLEN & HEATH
 KERNICK INDUSTRIAL ESTATE
 PENRYN
 CORNWALL
 ENGLAND TRIO 9LU

TEL. (44) (0) 1326 372070
 FAX. (44) (0) 1326 377097

DRAWING No. **C3632** ISSUE **3** **A2**

DANGER - HIGH VOLTAGE
 DISCONNECT POWER BEFORE REMOVING PSU
 REFER SERVICE WORK TO QUALIFIED SERVICE PERSONNEL ONLY

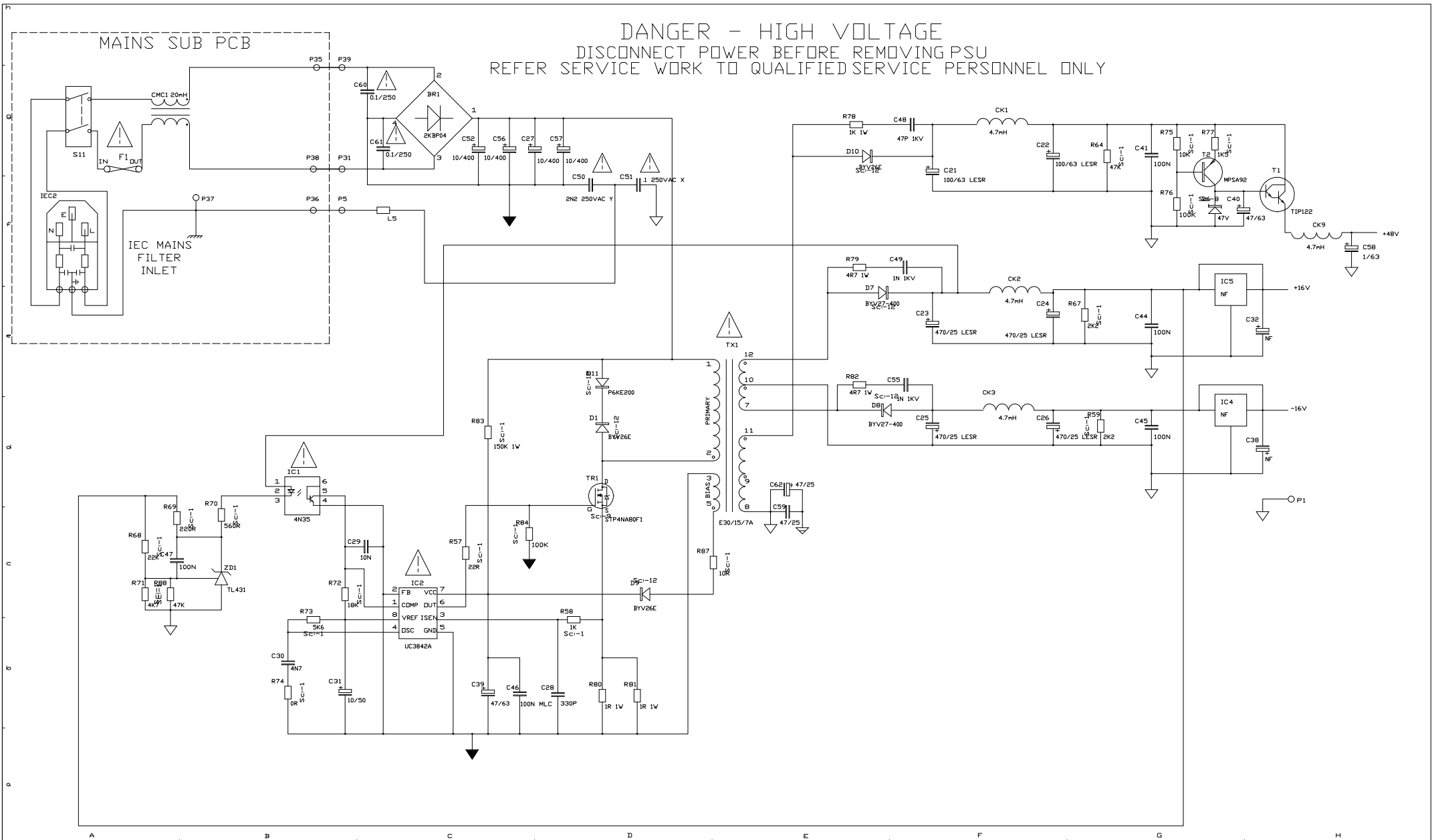

ISS.	REVISION	BY DATE	NOTES
1	PRODUCTION	AAT20-05-99	1. RESISTORS MARKED * ARE 1% ALL OTHERS ARE SZ 1/4W UNLESS OTHERWISE MARKED
2	EARTH PAD ADDED	AAT30-06-99	
2.1	NOISE PERFORMANCE	DWD27-07-99	
3	TRACK CUT MOD.	DWD26-08-99	2. ELECTROLYTIC CAPACITORS ARE 1%VOLT

UNIT TITLE
WIZARD 20 S
 PAGE 3 OF 3

DRAWING TITLE
CONNECTOR PCB
 PCB AG3401

ALLEN & HEATH
 KERNICK INDUSTRIAL ESTATE
 PENRYN
 CORNWALL
 ENGLAND TR10 9LU

TEL. (44) (0) 1326 372070
 FAX. (44) (0) 1326 377097

DRAWING No. **C3632** ISSUE **3** A2