



Logo Usage Guide

October 2013

Contents

Overview	3
Scale, Structure and Spacing	4
Colors: Offline and Online	7
Colors: Grayscale	8
Colors: One-color	9
Colors: Background	10
Fonts	11
Improper Uses (Do's and Don'ts)	12

Overview



The IAC Corporate logo and sector/segment logos are core components of the IAC brand. This document explains and outlines their proper use.

Scale, Structure and Spacing

Spacing

IAC Corporate Logo

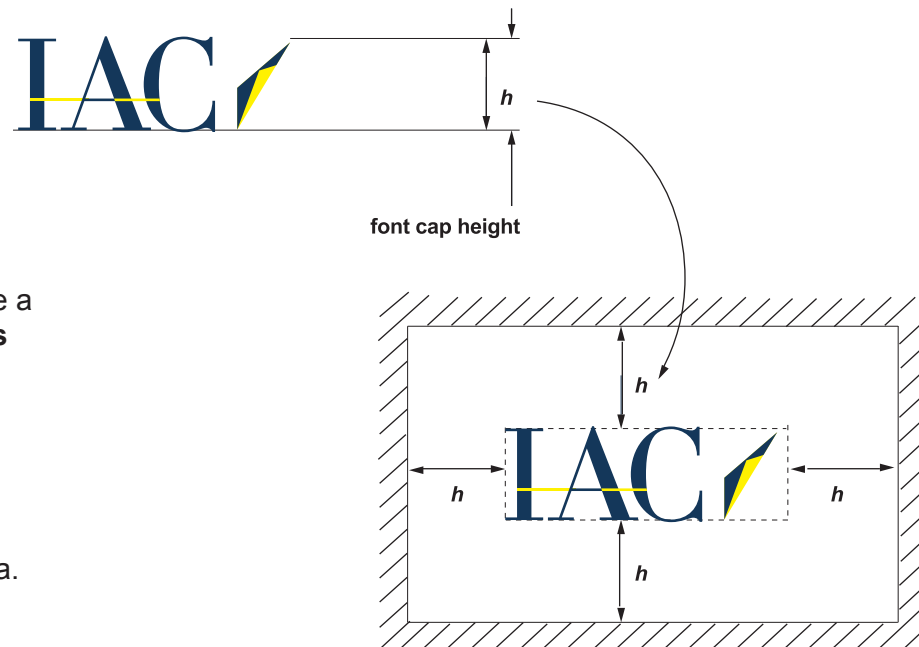

The IAC corporate logo should have a **margin of clear space on all sides** around it equal to the cap height of the IAC font (shown as h).

No objects (text, images, or other logos) can appear inside of this area.

Scale, Structure and Spacing [continued]

The IAC Corporate logo is composed of the IAC Mark.

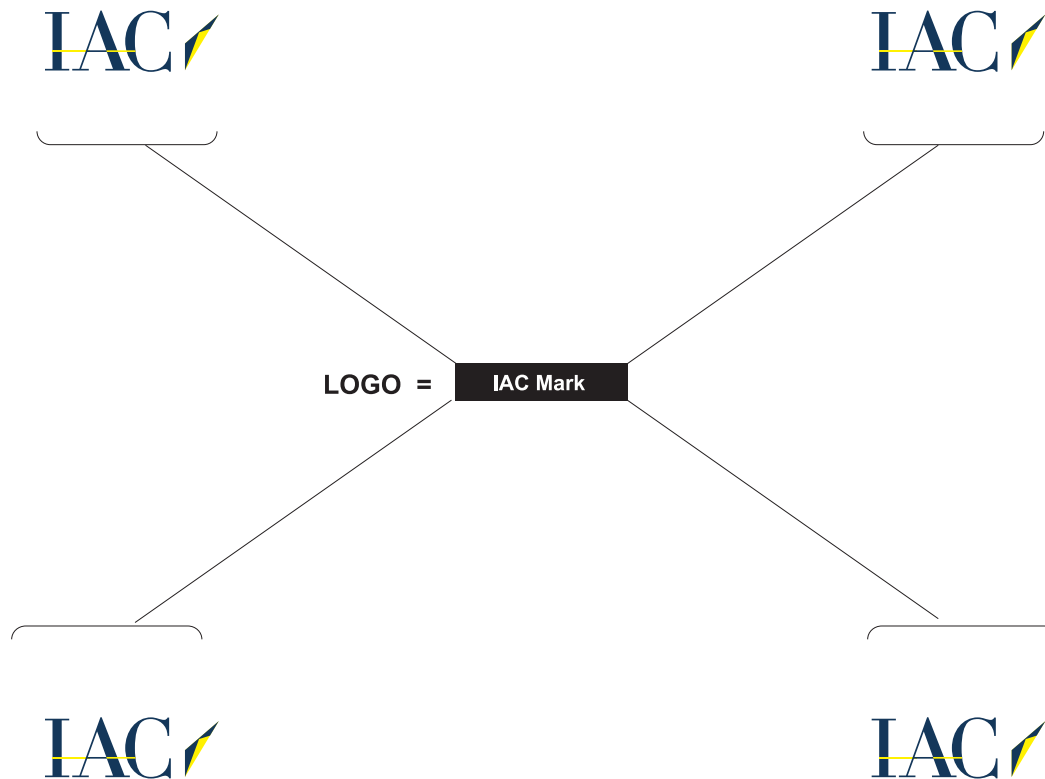

Scale, Structure and Spacing [continued]

IAC Corporate Logo

The I, A and C in the IAC Mark are always uppercase.



Colors: Offline and Online

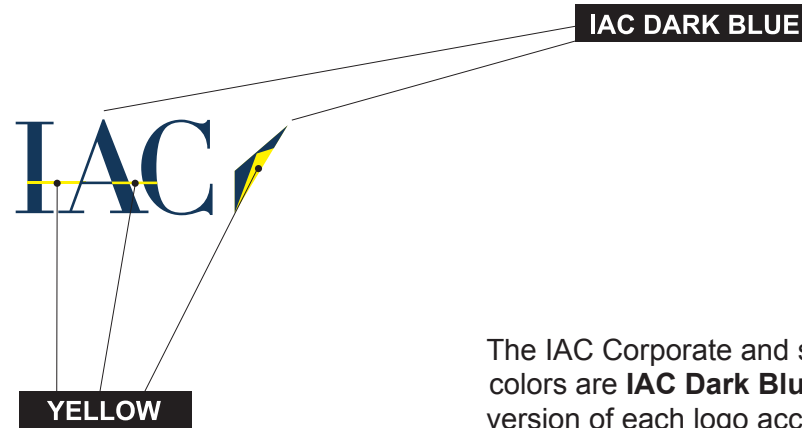

The IAC Corporate and sector/segment brand logo colors are **IAC Dark Blue** and **Yellow**. Use the appropriate version of each logo according to the type of application.

Print: Process

For four-color process (CMYK) print jobs, use the appropriate version of the logo with the color values below.

IAC DARK BLUE	CMYK 100, 64, 0, 60
---------------	-------------------------------

YELLOW	CMYK 0, 0, 100, 0
--------	-----------------------------

Print: Spot

For spot color print jobs, use the appropriate version of the logo with the color values below.

IAC DARK BLUE	PMS 289 BLUE
---------------	------------------------

YELLOW	PMS PANTONE YELLOW
--------	------------------------------

Online

For any online or screen applications, use the version of the logo with the color values below.

IAC DARK BLUE	RGB 0, 0, 51
	HEX 000033

YELLOW	RGB 255, 255, 0
	HEX FFFF00

Colors: Grayscale

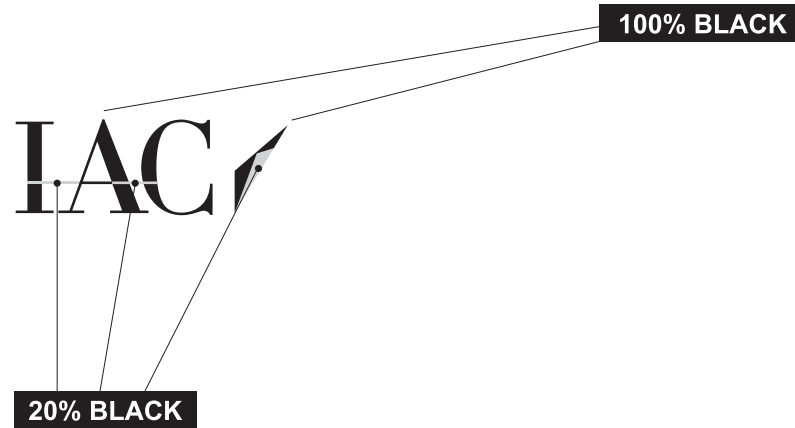

Print: Grayscale

For high resolution black and white printing, use the appropriate version of the logo with the color substitution values below.

IAC DARK BLUE	100% BLACK
---------------	-------------------

YELLOW	20% BLACK
--------	------------------

Colors: One-color



Print: One-color

For spot color print jobs or low resolution applications such as use in fax forms, use the appropriate version of the logo set entirely in black.

Colors: Background



Logo on a dark background

A one-color all-white version of the logo is used on dark backgrounds. A colored version of the logo must not be used because the contrast of yellow against white text is too subtle.



Logo on a light background

A colored version of the logo can be used over light backgrounds with low color saturation.

If used over a non-solid background (like a photograph or shaded field of color such as a gradient), special care must be given to placement. The logo must not be placed over areas of high relative contrast.

Fonts

IAC Regular ABCDEFGHIJKLMNOPQRSTUVWXYZ
& abcdefghijklmnopqrstuvwxyz

Improper Uses (Do's and Don'ts)



DO NOT change the logo element colors



DO NOT scale beyond a reasonable size

Improper Uses (Do's and Don'ts) [continued]



DO NOT place text after the IAC logo



DO NOT create your own language when using the IAC logo as a sub-brand.

PROPER USE

When using the IAC logo as a sub-brand, always use this treatment.

